

# Section Maker

Windows Version 14

User Manual



## License & Copyright

---

### Section Maker Program

© 1985-2011 Formation Design Systems Pty Ltd

Section Maker is copyrighted and all rights are reserved. The license for use is granted to the purchaser by Formation Design Systems as a single user license and does not permit the program to be used on more than one machine at one time. Copying of the program to other media is permitted for back-up purposes as long as all copies remain in the possession of the purchaser.

### Section Maker User Manual

© 1985-2011 Formation Design Systems Pty Ltd

All rights reserved. No part of this publication may be reproduced, transmitted, transcribed, stored in a retrieval system, or translated into any language in any form or by any means, without the written permission of Formation Design Systems. Formation Design Systems reserves the right to revise this publication from time to time and to make changes to the contents without obligation to notify any person or organization of such changes.

### DISCLAIMER OF WARRANTY

Neither Formation Design Systems, nor the author of this program and documentation are liable or responsible to the purchaser or user for loss or damage caused, or alleged to be caused, directly or indirectly by the software and its attendant documentation, including (but not limited to) interruption on service, loss of business, or anticipatory profits. No Formation Design Systems distributor, or agent, or employee is authorized to make any modification, extension, or addition to this warranty.



# Table of Contents

---

License & Copyright .....	iii
Table of Contents .....	v
About this Manual .....	1
Notation .....	3
Material Properties .....	3
Dimensions.....	3
Section Properties – Japan/International .....	3
Section Properties - United States.....	4
Section Properties – Europe (Eurocode) .....	5
Chapter 1 Introduction.....	7
About Section Maker .....	7
System Requirements .....	7
Installing Section Maker .....	7
Starting Section Maker .....	7
Section Property Calculations .....	7
Overlapping Shapes .....	7
Exact and Approximate properties.....	8
Composite Sections.....	9
Interaction with Multiframe .....	9
Sharing a library.....	9
The Frame Group.....	10
Chapter 2 Learning Section Maker.....	11
Starting Section Maker.....	11
Drawing a Shape .....	11
Placing a Shape.....	12
Placing a Section.....	13
Rotating the Shape .....	13
Dragging the Shape.....	14
Drawing a Shape.....	15
Selecting Materials .....	16
Aligning to the Centroid .....	17
Adding the Section to the Sections Library .....	17
Viewing Sections .....	18
Saving your Work.....	19
Printing your work .....	19
Chapter 3 Using Section Maker .....	21
Techniques .....	21
Summary of Mouse Techniques .....	21
Summary of Keyboard Techniques .....	22
Resizable Dialogs .....	23
Working in Shapes Window .....	24
Zoom.....	24
Pan .....	24
Shrinking the View .....	25
Sizing To Fit .....	25
Working in Table Windows .....	25
Column Widths.....	25
Text Styles .....	25
Number Styles.....	26
Changing Numbers or Name .....	26
Selecting Numbers in Tables .....	27

Copying and Pasting Numbers.....	27
Copying and Pasting Sections.....	28
Printing.....	28
Setting up the Printer .....	28
Printing a Window .....	29
Printing the Library.....	29
Chapter 4 Working with Shapes.....	31
Drawing a Shape .....	31
Setting the Size .....	32
Using the Grid.....	32
Drawing Tools .....	33
Moving a Shape .....	38
Moving a Number of Shapes .....	38
Moving Shapes Accurately .....	39
Copying and Pasting Shapes .....	39
Resizing a Shape .....	40
Deleting a Shape .....	40
Duplicating a Shape .....	40
Rotating a Shape .....	40
Rescaling a Shape .....	41
Reflecting Shapes.....	41
Making shapes equal in size.....	42
Aligning Shapes .....	42
Stacking Shapes .....	42
Converting Shapes to Polygons .....	43
Merging Polygons .....	43
Shape Properties.....	43
Grouping Shapes .....	44
Aligning to Centroid .....	44
Generating Standard Shapes .....	45
Fillet and Toes .....	45
Using Existing Sections .....	46
Importing a Shape .....	46
Setting Materials .....	47
Setting Material Types.....	47
Advanced Property Calculations.....	48
Viewing Properties.....	49
Validating the Shape .....	50
Adding a Section to the Library.....	50
Symbols.....	51
Shape Numbers .....	51
Polyline Numbers .....	51
Dimensions .....	52
Principal Axes.....	52
Axes .....	52
Fill.....	52
Material Patterns .....	52
Legend.....	53
Selecting Shapes .....	53
Position .....	53
Title Font.....	53
Font .....	54
Colours.....	55

Chapter 5 Sections Library Management .....	57
Working with Libraries .....	57
Fields and Section Properties .....	58
Creating a New Library .....	58
Opening a Library .....	58
Saving a Library.....	59
Saving as Text.....	59
Group Organiser .....	59
Working with Groups of Sections .....	61
Viewing Groups.....	61
Locking/Unlocking a Group of Sections .....	62
Adding a Sections Group .....	62
Editing a Sections Group .....	63
Duplicating a Group of Sections.....	64
Deleting a Group.....	64
Reordering Groups.....	65
Adding a Field .....	66
Editing Fields.....	66
Deleting a Field.....	68
Reordering Fields.....	68
Working with Sections.....	68
Viewing Sections .....	69
Adding a Section.....	69
Deleting a Section.....	70
Changing Section Properties.....	71
Custom Shape Data.....	73
Section Colour .....	73
Reordering Sections .....	73
Generating Tapered Sections .....	74
Working with Groups of Materials .....	76
Viewing Material Groups .....	76
Locking/Unlocking a Group of Materials.....	77
Adding a Materials Group .....	77
Editing a Materials Group.....	77
Duplicating a Group of Materials .....	78
Deleting a Group.....	78
Reordering Groups.....	79
Working with Materials .....	79
Viewing Materials.....	80
Adding a Material .....	80
Deleting a Material .....	80
Changing a Material.....	81
Reordering Materials .....	82
Material Colour.....	82
Chapter 6 Section Maker Reference.....	85
Windows .....	85
Shape Window.....	85
Data Window .....	85
Properties Window .....	85
Sections Window .....	85
Materials Window.....	85
Toolbars .....	85
File Toolbar.....	85

Group Toolbar.....	86
View Toolbar .....	86
Shape Toolbar .....	86
Geometry Toolbar.....	86
Symbols Toolbar.....	86
Menus.....	87
File Menu.....	87
Import Submenu .....	88
Export Submenu .....	89
Edit Menu .....	89
Select Submenu.....	90
View Menu .....	90
Geometry Menu .....	91
Make Equal Size Submenu .....	92
Align Submenu .....	93
Align to Centroid Submenu .....	93
Arrange Submenu .....	94
Shape Menu .....	94
Library Menu .....	95
Sections Submenu.....	95
Material Submenu.....	96
Display Menu.....	97
Properties Submenu .....	97
Data Submenu.....	98
Symbols Submenu .....	98
Colours Submenu.....	99
Legend Submenu .....	99
Window Menu .....	100
Help Menu .....	100
Appendix A - File Formats.....	101
Section Library Text File Format.....	101
References .....	103
Index.....	105

# About this Manual

---

This manual is about Section Maker, a section properties calculation and design system. Section Maker works with the Multiframe range of structural design software.

## [Chapter 1](#)

### [Introduction](#)

Provides an overview of the program and introduces you to some important concepts used within the program.

This chapter also discusses the numerical methods used by Section Maker. It is important for you to understand these methods and their limitations before using Section Maker for sections properties calculations.

## [Chapter 2](#)

### [Learning Section Maker](#)

Gets you started drawing, calculating properties and installing a section in the Multiframe Sections Library. In this chapter you will find a series of exercises designed to help you learn the basics of Section Maker and become confident in using it to design your own custom sections.

Once you are familiar with the basic concepts used, you may refer to the step-by-step instructions in Chapters 3, 4 and 5.

## [Chapter 3](#)

### [Using Section Maker](#)

This chapter introduces the basic techniques used to interact with the various windows in Section Maker.

## [Chapter 4](#)

This chapter explains most of the tasks you will carry out in designing and installing a new section into the sections library.

## [Chapter 5](#)

### [Sections Library Management](#)

Section Maker is also used to manage the content of Multiframe Section Libraries. This chapter describes how to edit the data in the library, how to add new sections and new groups of sections.

## [Chapter 6](#)

### [Section Maker Reference](#)

Gives an overview of the operations of Section Maker and a summary of the commands used.



## Notation

---

The following notation has been adopted within Section Maker.

## Material Properties

---

Property	Description
E	Young's Modulus
G	Shear Modulus
$\nu$	Poisson's ratio
Fy	Yield Stress
Fu	Ultimate Stress

## Dimensions

---

Property	Description
D	Depth
B	Width (or breadth)
tw	Web thickness
tf	Flange thickness
Fillet radius	Radius of fillets in the section
Toe radius	Radius of toes in the section
d1, d2	Minor depth dimensions
b1, b2	Minor width dimensions
taper	Taper angle
xl	Position of left extent of section
xr	Position of right extent of section
yt	Position of top extent of section
yb	Position of bottom extent of section

## Section Properties – Japan/International

---

Property	Description
Mass	Mass per unit length
Area	Cross sectional area
P	Distance around perimeter of section
xc, yc	Position of centroid
xs, ys	Position of shear centre
Ix	Moment of inertia about x axis
Iy	Moment of inertia about y axis
J	Torsion constant
Iw	Warping constant
Zxt	Elastic Modulus about x axis at top of section
Zxb	Elastic Modulus about x axis at bottom of section
Zyl	Elastic Modulus about y axis at left of section
Zyr	Elastic Modulus about y axis at right of section
rx	Radius of gyration about x axis
ry	Radius of gyration about y axis

<b>Property</b>	<b>Description</b>
Ixc	Mmt of inertia about x axis through centroid
Iyc	Mmt of inertia about y axis through centroid
Ixyc	Product of inertia about centroid
I1	Mmt of inertia about major axis through centroid
I2	Mmt of inertia about minor axis through centroid
Ø	Angle of major axis from x axis
Asx	Shear area for shear in the minor (x) direction
Asy	Shear area for shear in the major (y) direction
Z1t	Elastic Modulus about principal axis at top of section
Z1b	Elastic Modulus about principal axis at bottom of section
Z2l	Elastic Modulus about minor principal axis at left of section
Z2r	Elastic Modulus about minor principal axis at right of section
xp, yp	Position of plastic axis
Sx	Plastic Modulus about x-axis
Sy	Plastic Modulus about y-axis
S1	Plastic Modulus about major principal axis
S2	Plastic Modulus about minor principal axis

## **Section Properties - United States**

---

<b>Property</b>	<b>Description</b>
Mass	Mass per unit length
Area	Cross sectional area
P	Distance around perimeter of section
xc, yc	Position of centroid
xs, ys	Position of shear centre
Ix	Moment of inertia about x axis
Iy	Moment of inertia about y axis
J	Torsion constant
Cw	Warping constant
Sxt	Elastic Modulus about x axis at top of section
Sxb	Elastic Modulus about x axis at bottom of section
Syl	Elastic Modulus about y axis at left of section
Syr	Elastic Modulus about y axis at right of section
rx	Radius of gyration about x axis
ry	Radius of gyration about y axis
Ixc	Mmt of inertia about x axis through centroid
Iyc	Mmt of inertia about y axis through centroid
Ixyc	Product of inertia about centroid
I1	Mmt of inertia about major axis through centroid
I2	Mmt of inertia about minor axis through centroid
Ø	Angle of major axis from x axis
Asx	Shear area for shear in the minor (x) direction
Asy	Shear area for shear in the major (y) direction
S1t	Elastic Modulus about principal axis at top of section

<b>Property</b>	<b>Description</b>
S1b	Elastic Modulus about principal axis at bottom of section
S2l	Elastic Modulus about minor principal axis at left of section
S2r	Elastic Modulus about minor principal axis at right of section
xp, yp	Position of plastic axis
Zx	Plastic Modulus about y axis
Zx	Plastic Modulus about z axis
Z1	Plastic Modulus about major principal axis
Z2	Plastic Modulus about minor principal axis
R0	Polar radius of gyration about shear centre (See AISC LRFD Appendix E)
H	Flexural Constant (See AISC LRFD Appendix E)

### **Section Properties – Europe (Eurocode)**

---

<b>Property</b>	<b>Description</b>
Mass	Mass per unit length
Area	Cross sectional area
P	Distance around perimeter of section
yc, zc	Position of centroid
ys, zs	Position of shear centre
Iy	Moment of inertia about x axis
Iz	Moment of inertia about y axis
It	Torsion constant
Cw	Warping constant
Wel.y.1	Elastic Modulus about y axis at top of section
Wel.y.1	Elastic Modulus about y axis at bottom of section
Wel.z.2	Elastic Modulus about z axis at left of section
Wel.z.2	Elastic Modulus about z axis at right of section
Iy	Radius of gyration about y axis
Iz	Radius of gyration about z axis
Iyc	Mmt of inertia about y axis through centroid
Izc	Mmt of inertia about z axis through centroid
Iyzc	Product of inertia about centroid
Iu	Mmt of inertia about major axis through centroid
Iv	Mmt of inertia about minor axis through centroid
Ø	Angle of major axis from x axis
Asy	Shear area for shear in the minor (y) direction
Asz	Shear area for shear in the major (z) direction
Wel.u.1	Elastic Modulus about principal axis at top of section
Wel.u.2	Elastic Modulus about principal axis at bottom of section
Wel.v.1	Elastic Modulus about minor principal axis at left of section
Wel.v.2	Elastic Modulus about minor principal axis at right of section
yp, zp	Position of plastic axis

<b>Property</b>	<b>Description</b>
Wpl.y	Plastic Modulus about y-axis
Wpl.z	Plastic Modulus about z-axis

# Chapter 1

## Introduction

---

This chapter provides a brief introduction to Section Maker.

- [About Section Maker](#)
- [Installing Section Maker](#)
- [Section Property Calculations](#)
- [Interaction with Multiframe](#)

### About Section Maker

---

Section Maker may be used to calculate the sectional properties of arbitrary structural shapes and install them as sections in the Multiframe Sections Library.

### System Requirements

---

Section Maker will run on any Windows XP/ Windows Vista / Windows 7 computer .

### Installing Section Maker

---

Section Maker is installed as part of the Multiframe Suite installer. For instructions, please see: <http://www.formsys.com/installation> or the installation guide on the installation CD.

### Starting Section Maker

---

After installation, Section Maker should be accessible through the Start Menu. Simply select Section Maker from the Multiframe menu under the Start menu.

### Section Property Calculations

---

It is important that you understand the techniques used by Section Maker to calculate section properties. Before using the program, you should read the remainder of this chapter to ensure you understand how to model sections to get accurate results.

### Overlapping Shapes

---

If you create a section that is composed of a number of shapes you should be aware of how Section Maker treats these for calculation purposes.

First, don't partially overlap shapes, the properties won't be computed correctly. You may have a shape completely inside another or completely separate but they may not partially overlap.

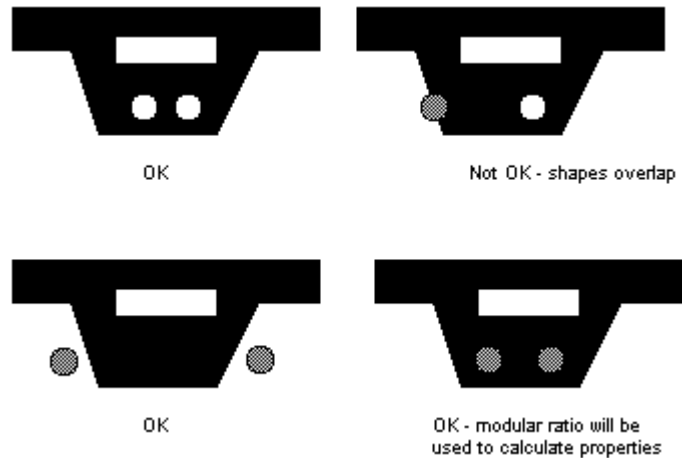

### Exact and Approximate properties

Most section properties computed by Section Maker are exact and are based upon the theory of plane areas. However, some properties cannot easily be computed for arbitrary section shapes and so it is necessary for Section Maker to identify a shape as one of the standard shapes. The following properties will only be determined correctly when Section Maker has identified a section as a standard section shape.

- **Shear Areas**
- **Torsion Constant and Torsion Modulus**
- **Warping Constant**
- **Shear Centre and derived properties**

To indicate that the  $J$  and  $I_w$  values are approximate, SectionMaker displays a \* character after the variable in the Properties window ( $J^*$  and  $I_w^*$ ).

If you use the Advanced calculations option from the Shape menu, SectionMaker uses a finite element analysis of the cross section to calculate an accurate value for  $J$  and  $I_w$ . When this method has been used, the \* character will not be displayed to indicate that the value shown is accurate. ( $J$  and  $I_w$ )

When installing a section of unknown shape the [Advanced Property Calculations](#) option can be used to accurately compute the torsion constant, warping constant and the location of the shear centre.

#### **IMPORTANT: Non-standard shapes**

When Section Maker does not identify the section drawn within the shape window as one of its standard section shapes some properties will not be computed correctly. When installing a section of unknown shape to the sections library the user should review the value of the following properties to ensure their accuracy.

Shear Areas – Approximated as gross area of section.

Torsion constant – Approximated as sum of torsion constant of shapes.

Warping Constant – Set to Zero.

Shear Centre – Assumed to be coincident with centroid.

H, r0 – LRFD properties based upon shear centre.

#### Note

The advanced calculations option can be used to accurately compute the torsion constant, warping constant and the location of the shear centre.

### Composite Sections

---

For a section composed of more than one material, Section Maker computes modulus weighted section properties as described in Pilkey. In determining the elastic properties of a section, the modulus weighted concept scales the properties of the individual shapes forming the section by the ratio of the elastic modulus of the shape and the elastic modulus of a reference material.

For example, a reinforced concrete section, Section Maker would default to using concrete as the reference material. In determining the overall properties of the section, the properties of the steel shapes would be factored by the modular ratio  $E_s/E_c$  where  $E_s$  is the Young's Modulus of the steel and  $E_c$  is the Young's Modulus of the concrete.

The calculation of the plastic properties, such as the plastic modulus, for a composite section uses a similar concept. Instead of scaling the properties of shapes by the ratio of the elastic moduli, the properties are factored by the ratio of the yield strength of the shape to the yield strength of the reference material.

### Interaction with Multiframe

---

When constructing a frame in Multiframe it is often necessary to use Section Maker to design the sections shapes used within the model. There are a number of ways to share or transfer data from Section Maker for use in Multiframe.

#### Sharing a library

---

Section Maker and Multiframe can open the same sections library simultaneously. As the sections library is a file, care must be exercised to avoid overwriting changes made in one program with changes made in the other. The simplest way to avoid this is to always modify the sections library using Section Maker and reload the updated library into Multiframe in order to use the new sections.

#### **IMPORTANT: Using Section Maker with Multiframe**

Be careful when using Section Maker with the Multiframe program open in the background. If you have both Section Maker and Multiframe open at the same time, any changes you make to the Section Library with Section Maker will not be reflected in the sections available to Multiframe until they are saved and re-loaded into Multiframe.

To make any changes to the library available within Multiframe you must

- **Save the section library from Section Maker using the Save command**
- **Switch to Multiframe**
- **Use Open Library->Sections Library from the File menu to re-load the saved library into Multiframe**

Note that it is not necessary to close the model open within Multiframe when opening the sections library. Multiframe will automatically locate sections used within the model within the updated library.

### **The Frame Group**

---

In Multiframe, an extra group of sections is added to the end of the sections library. This group, named the “Frame” group, is stored as part of the Multiframe model instead of within the sections library. As this group is not accessible from Section Maker, the only way of adding a section to this group is via the Add Section command within Multiframe. It is then necessary to copy the property data from Section Maker into the Add Section dialog open within Multiframe.

To facilitate this and enable the section property data to be readily exchanged, the Properties Window in Section Maker contains a table listing the properties of the Frame group. These properties can be copied directly from here and inserted into the table within the Add Section dialog. Care should be taken to ensure the same units are in use within both programs.

## Chapter 2

# Learning Section Maker

---

This chapter provides a tutorial to help you learn the basics of working with Section Maker.

- [Starting Section Maker](#)
- [Drawing a Shape](#)
- [Adding the Section to the Sections Library](#)

### Starting Section Maker

---

Start up the Section Maker program and then use the Drawing Layout command from the Window menu to lay out three windows on the screen titled Shape, Properties and Data. This will provide you with the most convenient window arrangement for creating new sections.

### Drawing a Shape

---

To introduce you to the concepts and techniques you will use in Section Maker, this chapter will describe the creation of a structural section step by step. The section you will draw is shown below.

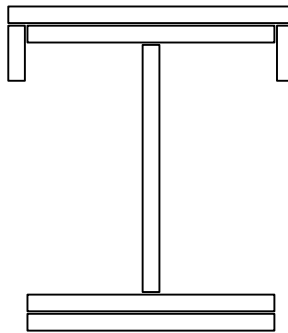

First, you will draw the section to scale, inside the Shape window. Make sure that your units are set up correctly by using the Units command from the View menu. This example is carried out in American units; you can use other units if you wish.

It is necessary to set up the sizes for drawing in the Shape window.

- **Choose Size... from the View menu.**

A dialog box will appear with four fields in it specifying the maximum dimensions of the section.

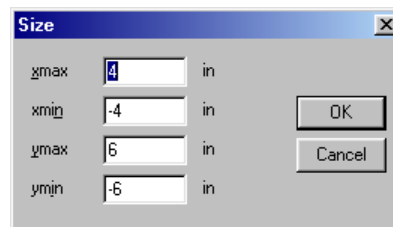

- **Type 4 for the maximum x coordinate and then press the Tab key to move to the second field**
- **Type in -4 for the minimum x coordinate and then use the Tab key to move to the next two fields entering 6 and -6 for the maximum and minimum y coordinates.**
- **Click the OK button when you have finished entering the values.**

If you make a mistake entering the numbers, you can use the backspace key to delete the character just to the left of the blinking cursor and you can use the Tab key to move from one field to the next.

### Placing a Shape

To create the I-beam that forms the basis of the section, you can use Section Maker's commands for automatically generating a common structural shape.

A note on terminology:

Section Maker uses the term "section" to refer to a structural cross sectional shape and its associated sectional properties that is stored in the Multiframe Sections Library. The term "shape" is used to refer to a geometric shape such as a polygon, circle or rectangle or an assemblage of these shapes. A section is made up of one or more shapes.

- **Choose Place Shape from the Shape menu.**

A dialog will appear with a picture of an I shape and fields where you can enter the dimensions of the shape.

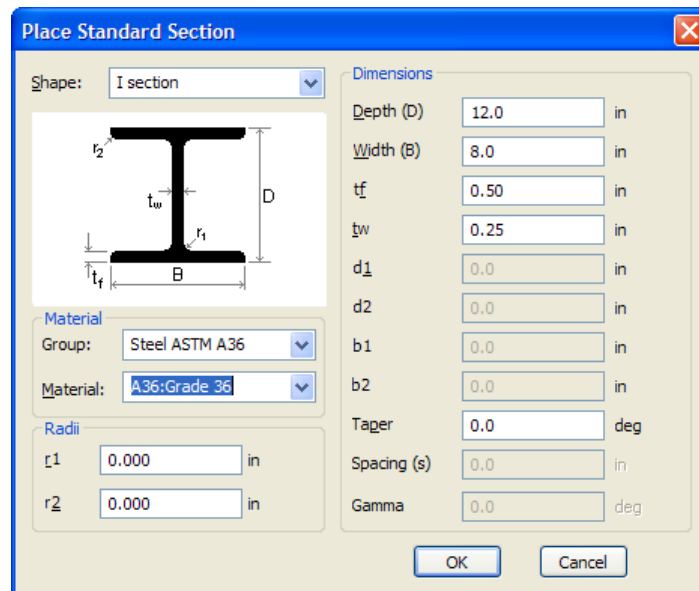

- **Choose Steel for the material type**
- **Type in 12 for the depth then enter 8 for the width, 0.5 for the flange thickness and 0.25 for the web thickness.**
- **Click the OK button**

The I shape will be drawn on the screen centred in the Shape window. The I shape is generated as an assembly of three rectangles. The corners of the rectangles will be highlighted with small black boxes (called handles) to indicate that the rectangles are selected.

**Note:**

The properties for the section are displayed in the Properties window.

### Placing a Section

To place the channel on the top of the I shape, you can take an existing channel from the Sections Library.

- **Choose Place Section... from the Shape menu**

A dialog will appear allowing you to select a section from the Sections Library

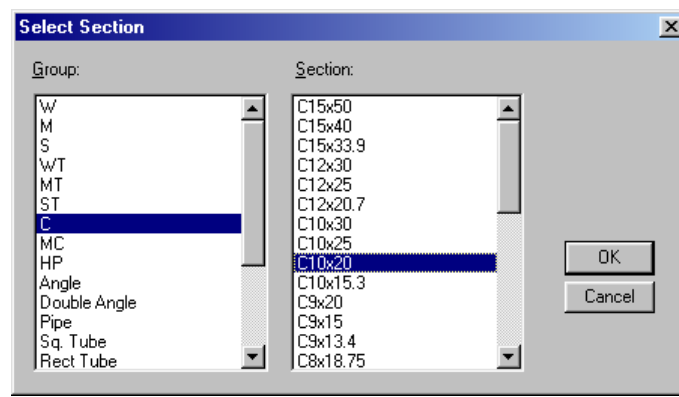

- **Click on the C name in the list of groups**

The names of the channel sections stored in this group will be displayed in the list on the right.

- **Click on the name C10x20 to select this section**
- **Click the OK button**

The dimensions of the section will be taken from the library and the section will be drawn in the centre of the Shape window. This C shape will be made up of three rectangles modelling the web and two flanges and two shapes modelling the fillets between the web and flange. The corners of the placed section will be highlighted to indicate that the group of shapes is selected.

### Rotating the Shape

Before you can place this C shape on top of the I shape, you need to rotate it by 90 degrees

- **Choose Rotate ... from the Geometry menu**

A dialog will appear allowing you to enter the number of degrees to rotate the shape. The angle of rotation is measured in degrees with positive being anti-clockwise

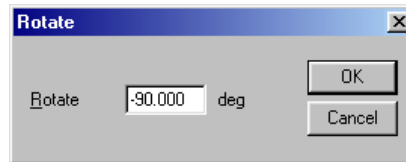

- **Type in -90 for the angle of rotation**
- **Click the OK button**

The C shape will be rotated so that it is oriented ready to move on to the top of the I shape.

### **Dragging the Shape**

---

You can move shapes in Section Maker by dragging them with the mouse.

To drag the C shape

- **Point anywhere inside the C shape but away from the black boxes, which show that it is selected.**
- **Press and hold down the mouse button.**

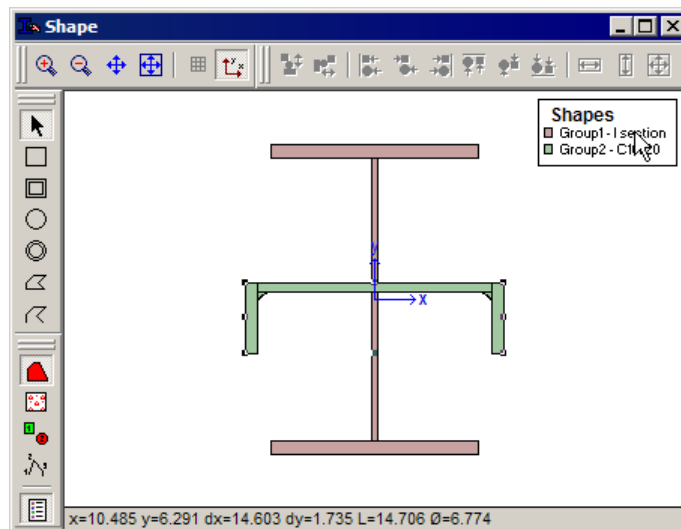

- **Drag the shape until its sits evenly on top of the I shape**

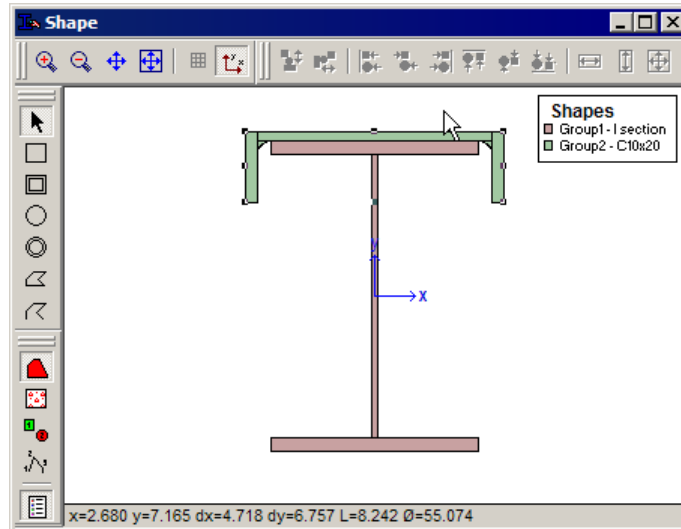

- **Release the mouse button.**

As you drag the shape it will be redrawn at its new position

At every change that you make to the section, the new section properties will be automatically recalculated and updated in the Properties window.

### Drawing a Shape

Now you can draw the additional plate on the bottom flange of the section.

To make it easier for you to draw the frame, you can use Section Maker's Grid option to make drawing automatically align to a grid with regular spacing.

- **Choose Grid... from the View menu.**

A dialog box will appear with values for the x (horizontal) and y (vertical) spacing of the grid.

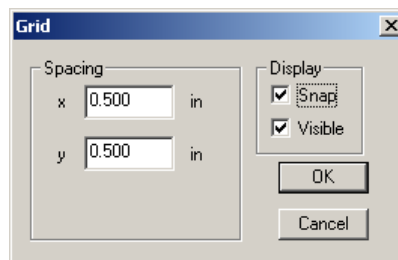

- **Type 0.5 for the x spacing, use the Tab key to move to the y spacing and type 0.5 for it also**
- **Click on the Visible check box to display the grid in the window.**
- **Click on the Snap check box to make subsequent drawing align with the grid.**

This will also turn on the Visible button to make the grid visible in the Shape window.

- **Click on the OK button to confirm your settings.**

Now move the pointer inside the Shape window and notice that as you move the mouse, the coordinates of the pointer are shown at the bottom left hand corner of the window. The coordinates are shown in the same units as Deflection in the Units dialog. The coordinates will automatically align to the nearest point on the grid. You can now begin to draw the shape to scale in the Shape window.

- **Click on the Rectangle tool to select it**



- **Press the mouse button at the bottom left corner of the I shape**
- **Drag down and to the right to draw the bottom plate**

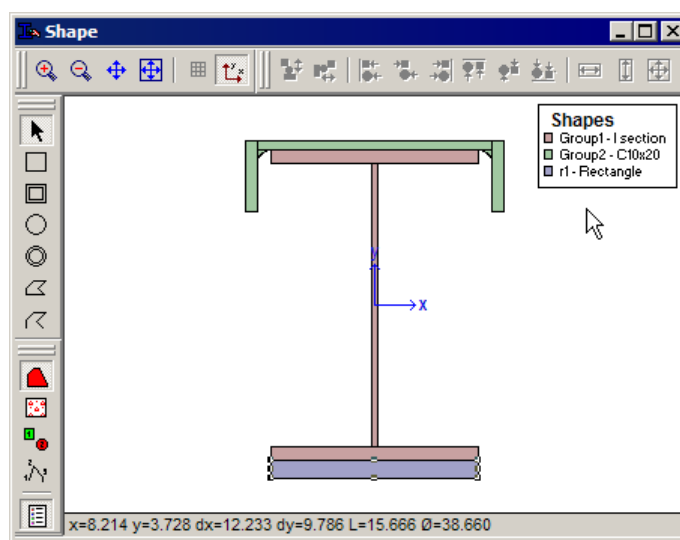

- **Release the mouse button when the plate is the correct size, i.e. when the coordinates read  $x=4, y=-6.5$**

Notice that the properties for the rectangle displayed in the Data window are negative. This is because as yet no material types have been assigned to that shape. Any shape, which does not have a material type, is assumed to be a hole and is subtracted from the property calculations. Next we will set the material for the rectangle.

### Selecting Materials

In order to compute the deflections in a structure, Multiframe needs to know the Young's Modulus and Shear Modulus for the materials in the section. You can choose what type of material each shape in the section is made of by choosing from the range of materials properties stored in the Sections Library.

The rectangle you have just drawn should be selected. If not, select it by clicking on it.

- **Choose Select Material from the Shape menu**

A dialog box will appear with a list of the materials in the library.

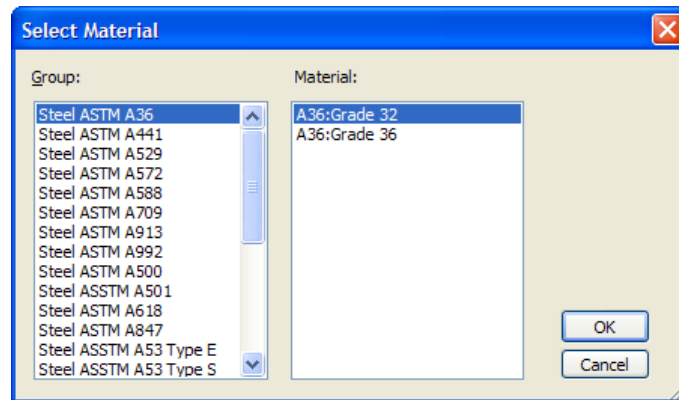

- **Click on the name of the group containing the materials in the left hand list**
- **Click on the name Steel in the list of the right hand side.**
- **Click the OK button**

This will define the bottom plate to take its material properties from those for steel stored in the library. The shapes will be drawn filled with the colour depending on shape type and patterned for their material, solid for steel in this case.

### **Aligning to the Centroid**

---

Before you install your section in the Sections Library you will probably want to align the Centroid of its area with the x-y axes so that all properties will be calculated relative to the Centroid.

To align the Centroid of the section with the axes

- **Choose Select -> All from the Select sub-menu under the Edit menu**

This will select all the shapes in the section

- **Choose Align To Centroid->Centroid from the Geometry menu**

All of the selected shapes in the Shape window will be moved so that their common Centroid is aligned with the x-y axes.

- **Choose Size To Fit from the View menu**

This will make the whole section visible in the window.

Once the shapes move, the properties will be automatically recalculated and displayed in the Properties window. You can check that the section is aligned with the axes by verifying that the coordinates of its Centroid ( $x_c$ ,  $y_c$ ) are 0.000,0.000.

### **Adding the Section to the Sections Library**

---

Now that you have created the section you want, you can install it in the Sections Library.

If Section Maker finds a library named "SectionsLibrary.slb" in the same directory as Section Maker, it will automatically open it on start-up.

If you have installed Section Maker correctly, this library should automatically have been opened.

➤ **Choose Add to Library... from the Shape menu**

A dialog box will appear with the properties of the section, a list of groups and a list of symbols indicating the shape of the section. The section's properties displayed in the table will be the same as those calculated in the Data window. If you wish you can change them before installing the section in the library. In this case we will leave them set to the calculated values.

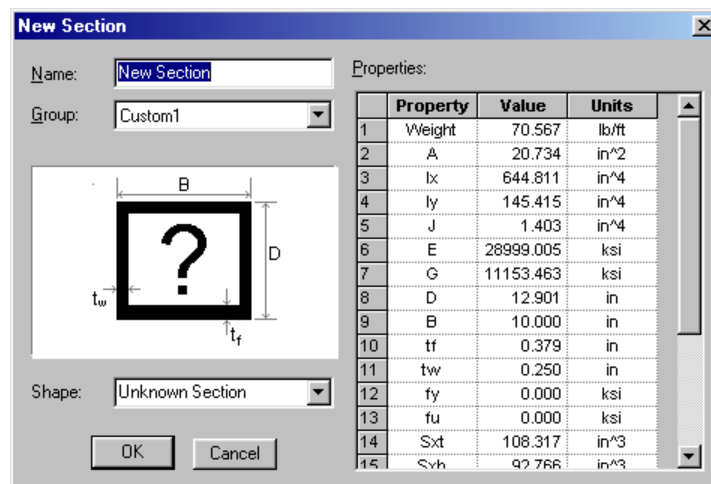

➤ **Type in a name for the section**

➤ **Select the name of the group where you would like to store the section eg Custom1**

Since it is not one of the standard shapes, in this case we will leave the shape set to the “Unknown Section” setting.

➤ **Click the OK button**

### Viewing Sections

You can verify that your section has been correctly installed into the library by checking its properties in the Tables in the Sections Window.

➤ **Choose Sections from the Window menu**

The Sections Window will be brought to the front.

➤ **Click on the tabs at the bottom of the Libraries Window**

Tables of sections are displayed in this window. Each group is displayed in a separate tab. Click on the tab with the name of the group to which the section was added at the bottom of the screen to display the sections

To choose which group to display

➤ **Click on the tab with the name of the group to which the section was added.**

The table of sections for that group will be displayed in the Sections Window. You can check the name and properties are correctly stored by scrolling through the table to view the section's name and properties.

### **Saving your Work**

---

You can save the changes you have made to the Section Library by using the Save command from the File menu.

- **Choose Save Library from the File menu**

The Sections Library will be saved to disk complete with the section you added to it.

### **Printing your work**

---

You can print the shape you have created

- **Bring the Shape window to the front**
- **Choose Page Setup from the File menu and choose your paper size**
- **Choose Print Window from the File menu**
- **Click the Print button to print out the shape**

This will print the shape on your printer. You can bring the Properties window to the front and use Print Window to print the properties table for the shape.



## Chapter 3

# Using Section Maker

---

If you have read Chapter 1 and 2, you are now familiar with some of the features of creating a section using Section Maker. The next three chapters describe all the commands available within Section Maker. They present a series of step-by-step instructions of the tasks covered in Chapter 2 as well as other procedures you will want to know about.

This chapter describes the basics of how to interact with the various windows used within Section Maker.

- [Summary of Mouse Techniques](#)
- [Summary of Keyboard Techniques](#)
- [Resizable Dialogs](#)
- [Working](#)
- [Working in Table](#)
- [Printing](#)

## Techniques

---

This section describes several techniques you can use in Section Maker.

- [Summary of Mouse Techniques](#)
- [Summary of Keyboard Techniques](#)
- [Resizable Dialogs](#)

See also:

- [Working in Shapes Window](#)
- [Working in Table Windows](#)

## Summary of Mouse Techniques

---

You will use the following mouse techniques to do just about all of the tasks in this chapter.

- **Click to select or activate something**
- **Press to cause a continuous action**
- **Drag to select, choose from a menu or move something**
- **Shift-Click to select or to extend or reduce a selection**
- **Double-Click to choose from a dialog box**

### To Click

Position the pointer on what you want to select or activate  
Press and quickly release the mouse button

### To Press

Position the pointer on something  
Without moving the mouse, press and hold down the mouse button.

The effects of pressing continue as long as the mouse button is held down. Pressing on a scroll arrow results in continuous scrolling. Pressing on a menu title pulls down the menu and keeps it down until you release the mouse button.

**To Drag**

Position the pointer on something  
Press and hold down the mouse button and move the mouse  
Release the mouse button.

**To Shift-Click or Ctrl-Click**

Shift-click is used to extend or reduce the selection. In the Shape Window this will select or deselect the shapes. Hold down the shift key and click on the shape you wish to add to the selection or which you wish to remove from the selection

**To Double-Click**

Double click is used as a short cut equivalent to opening the properties dialog.. In the Shape Window, point to the shape you wish to edit and then click twice quickly in succession without moving the mouse.

**To Scroll**

In the windows with tabular data, the mouse wheel can be used to scroll the view up or down.

**To Zoom**

In the Shape Windows the mouse wheel can be used to dynamically zoom the view within the Window.

**To scroll a table one line up or down**

Click the appropriate arrow at the top or bottom of the vertical scroll bar

**To scroll a table one column left or right**

Click the appropriate arrow at the left or right of the horizontal scroll bar

**To scroll a table continuously line by line**

Press the appropriate arrow at the top or bottom of the vertical scroll bar

**To scroll a table continuously column by column**

Press the appropriate arrow at the left or right of the horizontal scroll bar

**To scroll up or down by the windowful**

Click in the grey area above or below the scroll box in the vertical scroll bar.

**To scroll left or right by the windowful**

Click in the grey area to the left or right of the scroll box in the horizontal scroll bar.

**To go to the beginning or the end of the table**

Drag the scroll box to the top or the bottom of the vertical scroll bar.

**To go to the left or right hand edge of the table**

Drag the scroll box to the left or the right of the horizontal scroll bar.

**To go to any part of a large table**

Drag the scroll box to a place in the scroll bar that's about equivalent to where the data is in the table.

**Summary of Keyboard Techniques**

---

This section describes keyboard techniques you can use as shortcuts when using Section Maker.

**Tab**

You can use the Tab key to move horizontally within a table or to move from one field in a dialog to the next.

**Enter**

The Enter key can be used to confirm the entry of numbers into a table and is the same as clicking OK in a dialog.

**Arrow Keys**

The ↑ ← → ↓ keys may be used to move the selection in their respective directions in the Data or Result tables.

**Delete (Or Backspace)**

The Delete key may be used to delete the current selection. If nothing is selected and you are typing text or numbers, it will delete the character to the left of the blinking cursor. In the Shape window it will delete the currently selected shapes.

**Ctrl**

The Ctrl key may be held down while typing another key to choose a command from a menu without using the mouse. Menu items, which have a key to the right of the name, may be chosen in this way. For example, to choose Undo from the Edit Menu you could hold down the Ctrl key and type Z.

**Shift**

You can hold down the shift key while clicking on something to add it to the current selection or remove it from the selection if it is already selected.

Holding down the shift while drawing a member, dragging a member or dragging a joint will constrain the movement to be horizontal, vertical or at a 45 degree angle.

Holding down the shift key while starting up the application will reset the application (window sizes, toolbars etc) back to the default settings.

**Scrolling**

Scrolling is a technique for moving a table of data up, down, left or right in a window so that you can bring any part of the table into view.

**Resizable Dialogs**

---

Some of the dialogs in Section Maker can be resized to provide more room for some controls within the dialog. Generally dialogs with tables or list boxes will be resizable. A small icon in the bottom right hand corner of the dialog (as shown below) identifies dialogs that can be resized.



## Working in Shapes Window

---

The Shape Window is the only graphical window in Section Maker. This section describes the commands used to control what is displayed in the window and how that is displayed.

### Zoom

---

Zoom allows you to increase the size of the drawing in the Shape window.

- **Choose Zoom from the View Menu**
- **Move the pointer to the top left hand corner of the area you wish to view in close detail**
- **Drag a rectangle down and to the right, which encloses the area of interest, and release the mouse button**

The window's contents will be re-drawn to display the part of the shape contained in the rectangle you have drawn.

The mouse wheel may also be used to dynamically zoom the view within the Shape Window. By moving the mouse wheel, the view will move in or out.

### Pan

---

Pan allows you to shift the display of the shape within the window upwards, downwards, to the left or right.

- **Choose Pan from the View Menu.**

The cursor will change to a hand.

- **Press inside the window and hold down the mouse button**
- **Drag the drawing to its new location.**
- **Release the mouse button to re-draw the contents of the window.**

If not enough memory is available to move the image, a rectangle the size of the window will be moved around as you move the mouse.

The middle mouse button may also be used to dynamically pan the view within the Shape Window. To pan the view, depress with middle mouse button within the view and drag the mouse to pan the view. When the desired view is obtain simply release the mouse button to stop panning.

### **Shrinking the View**

---

Shrink allows you to decrease the size of the drawing on the screen.

➤ **Choose Shrink from the View Menu**

The drawing will shrink down to 50% of its current size and be re-drawn. If the Shift key is held down when the Shrink command is selected the drawing will shrink by only 20%.

### **Sizing To Fit**

---

Size To Fit automatically resizes the drawing in the Shape window so that the section just fits inside the window in the current view. This is most useful after you have been zooming, panning or shrinking as it returns you to a viewing scale that just fits the section inside the window.

### **Working in Table Windows**

---

There are 3 windows in Section Maker that display tabular information. The data for the library is displayed in tables in the Sections and Materials Window. Information about the geometry of the section drawn in the Shape Window is displayed in the Data window while the properties for this section are displayed in the Properties window.

Use the scroll bars on the side or on the bottom of the table to scroll through the table to view rows or columns that are not visible.

In this section:

- [Column Widths](#)
- [Text Styles](#)
- [Number Styles](#)
- [Changing Numbers or Name](#)
- [Selecting Numbers in Tables](#)
- [Copying and Pasting Numbers](#)
- [Copying and Pasting Sections](#)

#### **Column Widths**

---

If you want to change the width of a column in the table

- **Press on the line dividing the column's title from the next column**
- **Drag the column divider to make the column wider**
- **Release the mouse button**

#### **Text Styles**

---

If you wish you can change the font and text size used to display the numbers in the table by using the Font command from the View menu.

To change the font and/or size of the text in a table

- **Choose Font from the View menu**

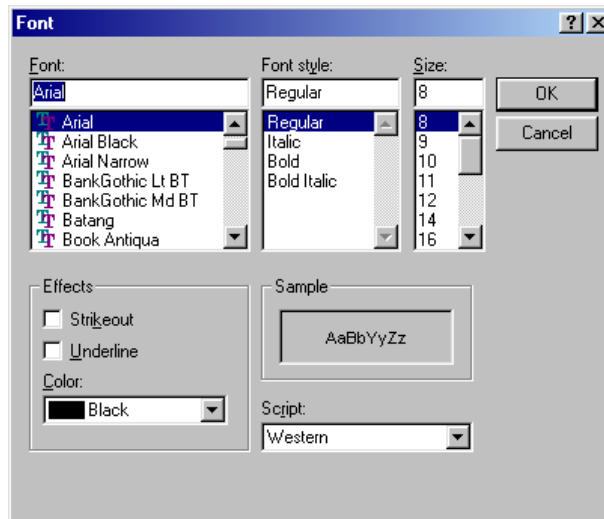

- **Click on the name of the font you require**
- **Click on a font size or type in a size**
- **Click the OK button**

### **Number Styles**

---

You can also choose what numeric format to use for displaying the numbers by using the Numbers command from the View menu.

To change the number of decimal places or the decimal format of the numbers in a table

- **Choose Numbers from the View menu**

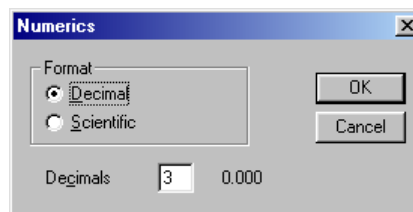

- **Choose Decimal or Scientific notation**
- **Type in the number of decimal places you require**
- **Click the OK button**

### **Changing Numbers or Name**

---

To change a number or name in a table

- **Click on the name or number to be changed**
- **Type in a new value**

- **Press the Enter key**

### **Selecting Numbers in Tables**

---

You can also copy and paste data in tables. The copy or paste will act on the current selection in the window. You can select a number or a range of numbers, a row or range of rows, or a column or range of columns.

To select a number

- **Click on the number**

To select a range of numbers

- **Press on the number at the top left of the range to be selected**
- **Drag the mouse until the last number is selected**
- **Release the mouse button.**

If the last number you want to select is outside the window, drag the mouse outside the window and the table will automatically scroll to bring the number into view.

To select a row

- **Click on the number at the left of the row**

To select a range of rows

- **Press in the number at the left of the first row**
- **Drag down until the last row is selected**
- **Release the mouse button**

If the last row is outside the window, drag outside the window and the table will scroll to bring the row into view.

To select a column

- **Click on the title at the top of the column**

To select a range of columns

- **Press in the title of the left hand column in the range**
- **Drag the mouse across until the right hand column is selected**
- **Release the mouse button**

If the right hand column is outside the window, drag outside the window and the table will scroll to bring the column into view.

To select the whole table

- **Click in the box at the top left corner of the table**

### **Copying and Pasting Numbers**

---

To copy or paste numbers in Section Maker, first select the numbers then choose the command you require.

To copy a number or range of numbers

- **Select the numbers to be copied**
- **Choose Copy from the Edit menu**

The numbers will be placed on the clipboard. Each row of numbers will have a return character at the end and the numbers in the row will be separated by a Tab character. You can transfer data copied from Section Maker into other programs or you can paste them into other tables in Section Maker.

To paste the numbers on the clipboard into a table

- **Select the numbers in the table that will be replaced by the numbers on the clipboard**
- **Choose Paste from the Edit menu**

### **Copying and Pasting Sections**

---

The table in the Sections Window can be used to copy sections between groups or even into the same group.

To copy a section or a number of sections to another group

- **Select the entire row of the sections to be copied**
- **Choose Copy from the Edit menu**
- **Select a new current group from the Group toolbar or by using the Select Group... command in the Library menu.**
- **Choose Paste Special from the Edit menu**

The copied sections will be appended to the end of the current group. Section Maker will make automatically map the section properties of the sections to the match the fields of the group into which they have been pasted. Caution should be exercised when copying sections between groups to ensure that section property data is not lost and that the data is available for all the fields in the destination group.

### **Printing**

---

The contents of any of the windows in Section Maker can be printed and you can also print out a complete table of every section in the Sections Library. When printing tables they will be printed over multiple pages as there will generally not be enough room on one page for all the rows and columns in the table.

#### **Setting up the Printer**

---

Before printing you should set up the printer with the page size and orientation that you wish to use.

To Set up the Printer

- **Choose Page Setup from the File menu**

The standard page setup dialog will appear allowing you to enter the appropriate information. You may also enter text to be displayed at the head and foot of each page and set the width of the margins on the page.

### **Printing a Window**

---

To print the contents of the front window

- **Choose Print Window from the File menu**

The standard print preview dialog will appear. Click the Print button to print out the contents of the front window.

### **Printing the Library**

---

To print the entire contents of the Sections Library

- **Choose Print Library from the File menu**

The standard print preview dialog will appear. Click the Print button to print out the library. The tables of sections for each group in the library will be printed. If there are more rows and columns than will fit one a page the printout will be spread over a number of pages.



## Chapter 4

# Working with Shapes

---

Creating a section with Section Maker involves defining the geometry of the shapes by drawing in the Shape window. You can also use the pre-defined generation aids to automatically place common structural shapes into the section.

In this section:

- [Drawing a Shape](#)
- [Moving a Shape](#)
- [Copying and Pasting Shapes](#)
- [Resizing a Shape](#)
- [Deleting a Shape](#)
- [Duplicating a Shape](#)
- [Rotating a Shape](#)
- [Rescaling a Shape](#)
- [Reflecting Shapes](#)
- [Making shapes equal in size](#)
- [Aligning Shapes](#)
- [Stacking Shapes](#)
- [Converting Shapes to Polygons](#)
- [Merging Polygons](#)
- [Shape Properties](#)
- [Grouping Shapes](#)
- [Aligning to Centroid](#)
- [Generating Standard Shapes](#)
- [Using Existing Sections](#)
- [Importing a Shape](#)
- [Setting Materials](#)
- [Advanced Property Calculations](#)
- [Viewing Properties](#)
- [Validating the Shape](#)
- [Adding a Section to the Library](#)
- [Symbols](#)
- [Legend](#)

### Drawing a Shape

---

The shapes, which make up a section, may be drawn directly in the Shape window.

The scale at which this drawing is carried out may be specified by choosing the Size... command from the View Menu. The maximum and minimum coordinates to be used in the x and y directions may be entered and Section Maker will scale these coordinates to the current size of the Shape window. All movements in the window are accompanied by a display of the current pointer coordinates in the lower left hand corner of the window. All coordinates are shown in the current units. You can change units using the Units command from the View menu.

### Setting the Size

---

Before starting drawing, you will need to set up the drawing area for the size of section you intend working with. To do this

- **Choose Size...from the View Menu...**

A dialog box will appear with the dimensions of the section

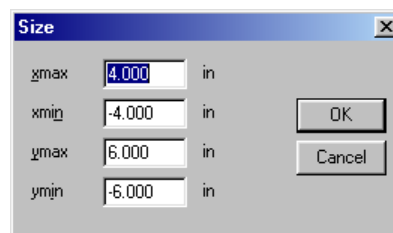

- **Enter the maximum and minimum coordinates you wish to use in each direction**
- **Click the OK button**

### Using the Grid

---

Section Maker has a built-in facility to allow you to have your drawing automatically align with an evenly spaced grid. You can control the spacing, display and use of this grid with the Grid command from the View Menu.

- **Choose Grid... from the View Menu**
- **Type in values for the x and y spacing of the grid**
- **Click on the On button if you want drawing to align to the grid**

This will switch on the Visible button to make the grid to visible.

- **Click the OK button**

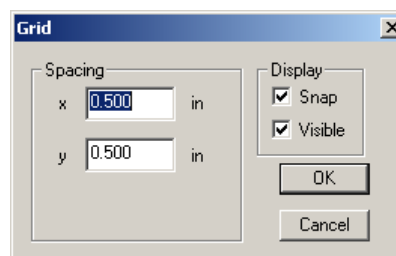

If you want to have the shapes automatically align with the grid but don't want to see the grid, simply click on the Invisible button before clicking OK. Similarly you can click on the Visible button to have the grid displayed as a visual guide but click on the Off button to disable the automatic alignment with the grid.

All drawing and dragging in the Shape window will align to the grid while the grid is switched on.

### Drawing Tools

Section Maker has six drawing tools for drawing different types of shapes. A change in background colour surrounding the tool's icon indicates the drawing tool which is currently active. If the Arrow tool is selected this allows you to select, move and resize shapes with the mouse.

Before you start drawing a new section, if there are any shapes in the Shape window Choose Select All from the Select sub-menu under the Edit menu and press the Delete key. This will remove the existing shapes.

### Rectangle Tool

The rectangle tool can be used for drawing solid rectangular shapes or for drawing rectangular holes in a section.

To draw a rectangle

- **Click on the rectangle tool to select it**

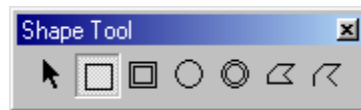

- **Press at the position of the top left corner of the rectangle you wish to draw**
- **Drag down to the right until the mouse points to the bottom right corner of your rectangle**

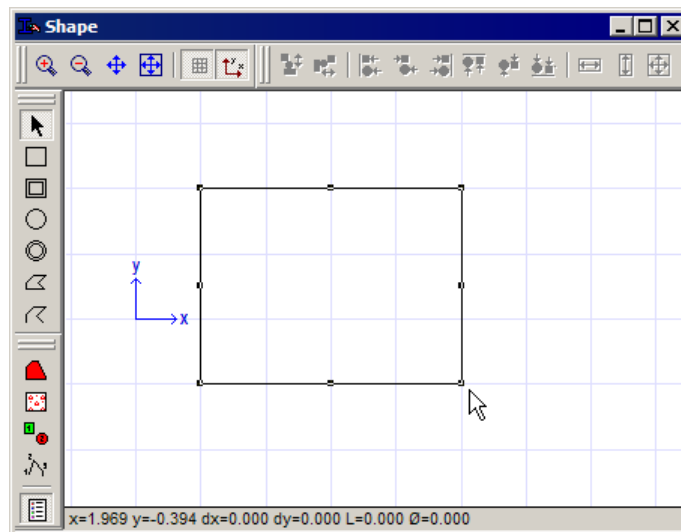

- **Release the mouse button**

If you have the Grid turned on then the corners of the rectangle will align to the grid. The new shape will be immediately added to the list of shapes displayed in the Data window.

### Hollow Rectangle Tool

The hollow rectangle tool can be used for drawing hollow rectangular shapes (rectangular or square structural tubing).

To draw a hollow rectangle

- **Click on the hollow rectangle tool to select it**



- **Press at the position of the top left corner of the rectangle you wish to draw**
- **Drag down to the right until the mouse points to the bottom right corner of your rectangle**

If you have the Grid turned on then the corners of the rectangle will align to the grid.

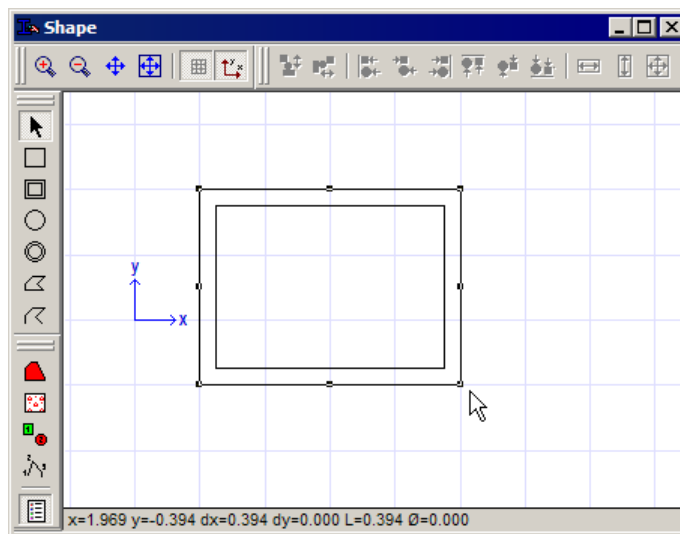

- **Release the mouse button**

When you release the mouse button a dialog will appear allowing you to enter the wall thicknesses of the shape you have drawn

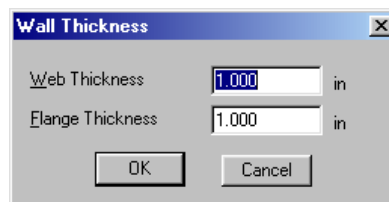

- **Type in values for the web and flange thicknesses**
- **Click the OK button**

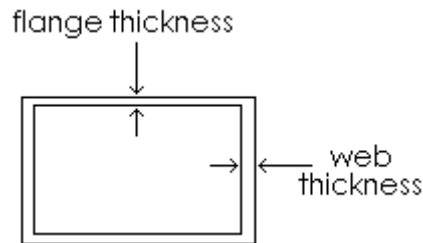

The new shape will be immediately added to the list of shapes displayed in the Data window.

### Circle Tool

The circle tool can be used for drawing solid circular shapes or for drawing circular holes in a section.

To draw a circle

- **Click on the circle tool to select it**



- **Press at the position of the centre of the circle you wish to draw**
- **Drag down outwards from the centre until the mouse points to the radius you require**

If you have the Grid turned on then the centre and radius of the circle will align to the grid.

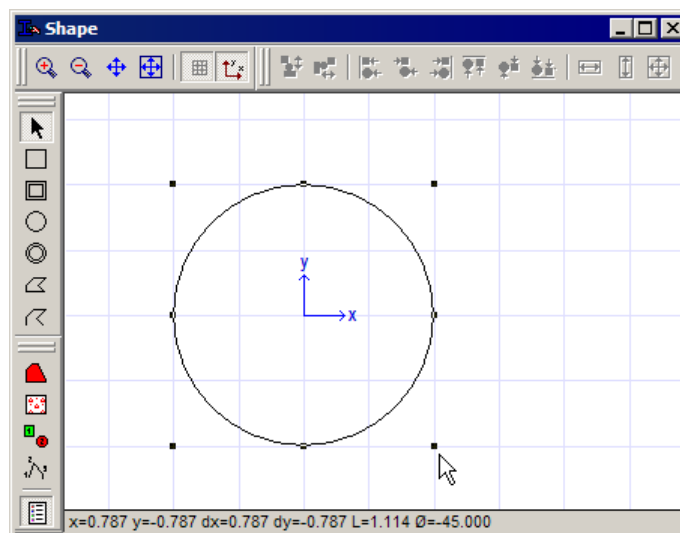

- **Release the mouse button**

The new shape will be immediately added to the list of shapes displayed in the Data window.

### Tube Tool

The tube tool can be used for drawing hollow circular shapes or tubes.

To draw a tube

- **Click on the tube tool to select it**



- **Press at the position of the centre of the tube you wish to draw**
- **Drag down outwards from the centre until the mouse points to the radius you require**

If you have the Grid turned on then the centre of the circle and the position of the circle will align to the grid.

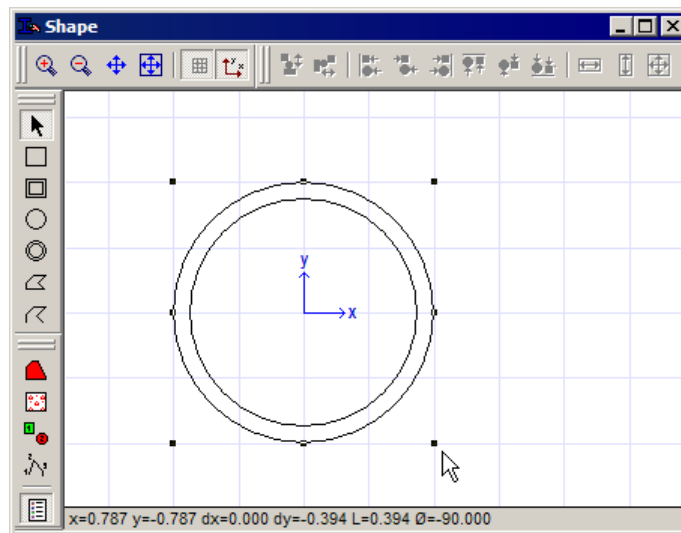

- **Release the mouse button**

A dialog will appear allowing you to enter a wall thickness for the tube.



- **Type in a value for the wall thickness**
- **Click the OK button**

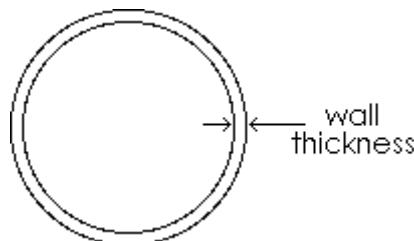

The new shape will be immediately added to the list of shapes displayed in the Data window.

### Polygon Tool

The polygon tool can be used for drawing solid polygonal shapes or for drawing polygonal holes in a section. Note that the calculation of sections properties for a polygon will be accurate for all properties except for the torsion constant  $J$ . For convex polygons the calculation of  $J$  will be a reasonable approximation however for any polygon with one or more re-entrant corners the calculation of  $J$  can not be relied upon.

To draw a polygon

- Click on the polygon tool to select it

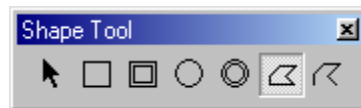

- Click at the location of the first vertex of the polygon

The first side of the polygon will be drawn as you move the mouse

- Click at the location of each of the other vertices of the polygon
- Double click at the location of the last vertex to close the polygon or ...
- Press Enter to close the polygon or ...
- Click close to the first vertex to close the polygon

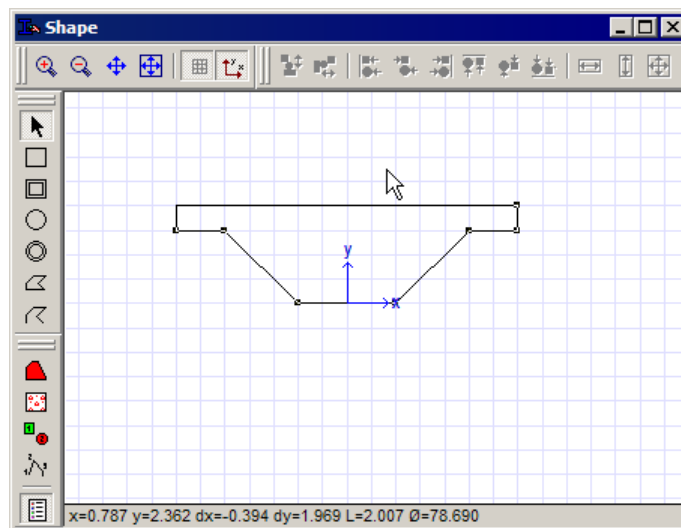

If you have the Grid turned on then the vertices of the polygon will align to the grid. The new shape will be immediately added to the list of shapes displayed in the Data window.

### Open Polygon Tool

The open polygon tool can be used for drawing polygonal shapes made of thin material. Thin means the thickness of the material is very small compared with the size of the shape. This is most useful for modelling structural shapes made from cold rolled thin steel or aluminium.

To draw an open polygon

- Click on the open polygon tool to select it

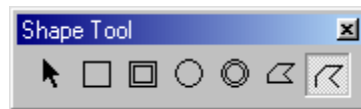

- **Click at the location of the first vertex of the polygon**

The first side of the polygon will be drawn as you move the mouse

- **Click at the location of each of the other vertices of the polygon**
- **Double click at the location of the last vertex to complete the polygon or ...**
- **Press Enter to complete the polygon**

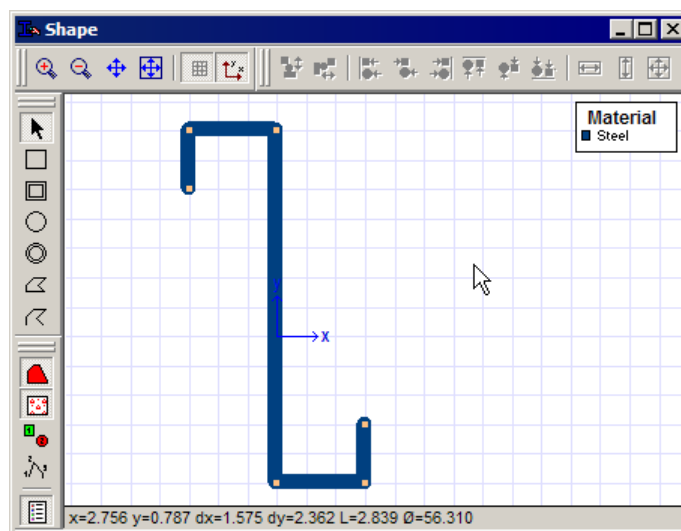

If you have the Grid turned on then the vertices of the polygon will align to the grid. The new shape will be immediately added to the list of shapes displayed in the Data window.

## **Moving a Shape**

---

You can move a shape by dragging it with the mouse in the Shape window

To move a shape

- **Point anywhere inside the shape**
- **Press the mouse button**
- **Drag the shape to the new location**
- **Release the mouse button**

Holding down the shift key while you drag will constrain the movement to be vertical or horizontal.

## **Moving a Number of Shapes**

---

You can move a number of shapes at once by selecting them and dragging them to the new location with the mouse.

To select a shape

- **Click on or in the shape with the mouse**

If you have turned off the display of materials, you must click on the boundary of the shape rather than inside it. The shapes handles will be highlighted to indicate that it is selected.

To add a shape to the current selection

- **Shift-click on or in the shape**

To move a number of shapes

- **Select the shapes to be moved**
- **Press on or inside any one of the selected shapes**

If you have turned off the display of materials, you must click on the boundary of a shape rather than inside one

- **Drag the shapes to their new location**
- **Release the mouse button**

The shapes will be re-drawn in their new position.

### **Moving Shapes Accurately**

You can also move the selected shapes with great accuracy by using the Move command from the Geometry menu.

- **Choose Move from the Geometry menu**

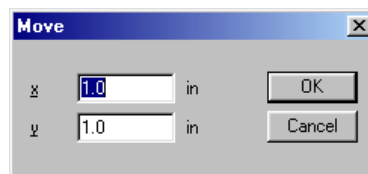

- **Type in the distance to move in each direction**
- **Click the OK button**

### **Copying and Pasting Shapes**

To copy a shape or shapes in the section

- **Select the shape or shapes to be duplicated**
- **Choose Copy from the Edit menu or press Ctrl+v**

The selected shapes are placed on the clipboard. To paste the shapes stored on the clipboard into the Shape Window

- **Choose Paste from the Edit menu or press Ctrl+v**

The duplicated shapes inserted into the Shape window slightly offset from there original position.

## Resizing a Shape

---

You can change the size of a shape by dragging its handles (the small black boxes which appear when it is selected).

To resize a shape

- **Press on the handle closest to the part of the shape you want to move**
- **Drag the handle to its new location**
- **Release the mouse button**

When you resize a polygon each of the vertices moves independently of the others.

## Deleting a Shape

---

To delete a shape or shapes from the section

- **Select the shape or shapes to be deleted**
- **Press the Delete key or ...**
- **Choose Delete from the Edit menu**

## Duplicating a Shape

---

To duplicate a shape or shapes in the section

- **Select the shape or shapes to be duplicated**
- **Choose Duplicate from the Geometry menu**

A dialog box will appear allowing you to specify the spacing of the duplicated shapes and how many are to be created

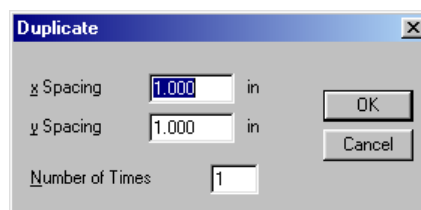

- **Type in the spacing in each direction and the number of duplicates**
- **Click the OK button**

The duplicated shapes will be drawn and selected in the Shape window.

## Rotating a Shape

---

Section Maker allows you to rotate shapes that you have already drawn. Shapes are rotated about the axes at an angle measured positive in the anti-clockwise direction. Rectangles may only be rotated in increments of 90 degrees.

To rotate a shape or shapes

- **Select the shape or shapes to be rotated**

- **Choose Rotate from the Geometry menu**

A dialog box will appear with a field for the angle of rotation

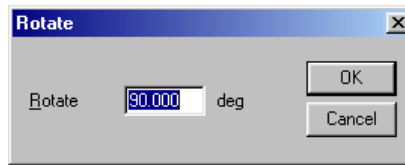

- **Type in the angle of rotation**
- **Click the OK button**

The selected shapes will be rotated about the origin of the axes and re-drawn in the Shape window

## Rescaling a Shape

---

Section Maker allows you to rescale shapes that you have already drawn. The coordinates of the shapes are multiplied by a scaling factor in each direction to rescale the shape.

To rescale a shape or shapes

- **Select the shape or shapes to be rescaled**
- **Choose Rescale from the Geometry menu**

A dialog box will appear with two fields for the scaling factor in each direction

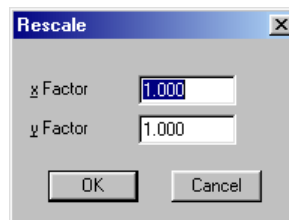

- **Type in the x and y scaling factors**
- **Click the OK button**

The selected shapes will be rescaled and redrawn in the Shape window

## Reflecting Shapes

---

You can reflect shapes in Section Maker by using the Flip Horizontal and Flip Vertical commands from the Geometry menu

To reflect the selected shapes about a vertical axis passing through the centre of area of the selected shapes

- **Choose Flip Horizontal from the Geometry menu**

To reflect the selected shapes about a horizontal axis passing through the centre of area of the selected shapes

- **Choose Flip Vertical from the Geometry menu**

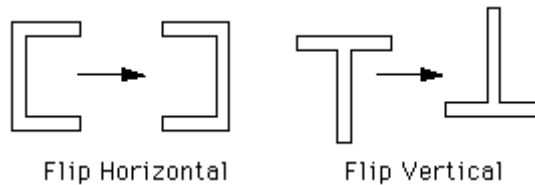

## Making shapes equal in size

---

You can also change width or height of a shape by making it equal in size to another shape.

To make a shape of a number of shapes equal in width

- **Select the shapes to be made equal in size. The first shape selected will be the dominant shape to which the others will be resized.**
- **Choose Width from the Make Equal Size submenu under the Geometry menu, or**
- **Click on the Make Equal Width button in the Geometry toolbar**

Each of the shapes will be resized so that they have the same width as the dominant shape. A similar procedure can be followed to make shapes equal in height or equal in both width and height by using other commands from the Make Equal Size submenu.

## Aligning Shapes

---

The Align commands moves the selected shapes so that the edges or centres of the shapes align to the edges or centres of the first shape selected. The Align submenu has commands for aligning the top, bottom, left and right hand edges of shapes. It also has commands to align the centres of shapes by moving the shapes either horizontally or vertically.

To align the left-hand side of a number of shapes

- **Select the shapes to be aligned. The first shape selected will be the dominant shape to which the others will be aligned.**
- **Choose Left from the Align submenu under the Geometry menu, or**
- **Click on the Align Left button in the Geometry toolbar**

Each of the shapes will be moved so that left hand side of each shape is aligned to the left hand side of the dominant shape. A similar procedure can be followed to align other sides of shapes by using other commands from the Align submenu.

## Stacking Shapes

---

The Stack commands, which complement the Align commands, move the selected shapes so that shapes are arranged from left to right or top to bottom such that adjoining edges aligned to one another. By stacking shapes horizontally, the select shapes will be moved so that they are arranged from left to right, the right-hand edge of left most shape will be aligned to the left-hand edges of the next and so forth. The first select shape will remain in its original position and all the other shapes will be arranged around it.

To vertically stack a number of shapes

- **Select the shapes to be stacked. The first shape selected will be the dominant shape about which the others will be rearranged.**
- **Choose Stack Vertically from the Geometry menu, or**
- **Click on the Stack Vertically button in the Geometry toolbar**

Each of the shapes will be moved vertically so that top of one shape is aligned to the bottom of the adjacent shape.

## **Converting Shapes to Polygons**

---

Shapes other than polygon shapes can be converted to closed polygons using the Convert to Polygon command in the Shape menu. While it is not recommended that shapes be converted to polygons, it can be useful to do this in a number of situation such as to allow shapes to be rotated by arbitrary angles or to generate complex shapes by merging over lapping polygon shapes.

To convert a number of shapes into polygons

- **Select the shapes to be converted.**
- **Choose Convert to Polygon from the Shape menu.**

Each of the shapes will be converted to a polygon.

## **Merging Polygons**

---

Polygons can be merged together to form complex shapes. Open polygons and closed polygons cannot be merged together; they can only be joined to other polygons of the same type. Open polygons will be joined to other open polygons only if they have a common end point. Closed polygon shapes can be merged with other closed polygons. The result may not be a single polygon as the merged shape will take into account which polygons are solid and which represent holes in the shape. However, no distinction is made between different materials and so any resulting solid polygons will be allocated a single material.

To merge a number of polygons

- **Select the polygons to be merged together.**
- **Choose Merge Polygon from the Shape menu.**

The selected shapes will be merged together to form a number of other polygons.

## **Shape Properties**

---

The properties of any shape can be modified by double clicking on the shape. This will open a property dialog that contains the dimensions and location of the shape. This dialog may also be opened by selecting a shape and choosing the Properties menu command from the Edit menu or the Properties command from the right-click context sensitive menu.

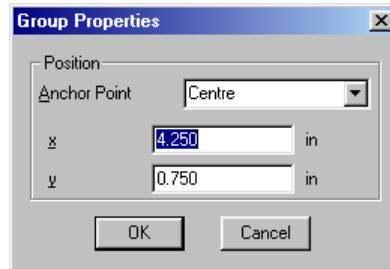

This dialog also lets you reposition shapes by specifying the location of an anchor point on the shape. This makes it easy to align shapes to other shapes within the section. The anchor point you choose is moved to the location you enter in this dialog.. For example, if you wanted to move a plate to just sit on top of the top flange of a beam, you would double click on the plate, choose the anchor point to be Bottom-Centre and set the x coordinate to zero and the y coordinate to the height of the top of the flange of the beam.

## Grouping Shapes

---

Section Maker allows you to group together shapes within the Shape View. This allows shapes to be manipulated together as a single item. This grouping is hierarchical so groups may also be grouped inside other groups.

To group together a number of shapes

- **Select the shapes to be grouped**
- **Choose Group from the Geometry menu**

To ungroup a group of shapes

- **Select the shape group**
- **Choose Ungroup from the Geometry menu**

When placing a section or shape within the Shape View, the basic shapes representing the section or shape will automatically be grouped together as a single item. When placing a section from a library, the group will store the name of the section and display this in the Kind column in the Data table. If, however, the shape is ungrouped, this information will be lost.

## Aligning to Centroid

---

Most times when you create a section you will want to calculate its properties relative to a set of axes at the centroid of its area. The Align To Centroid command moves all of the selected shapes so that their common centre of area is aligned with the origin of the axes. After using Align To Centroid the coordinates of the centroid of the selected shapes will always be  $x=0,y=0$ .

To align the centroid of a shape or shapes with the axis origin

- **Select the shape or shapes to be aligned**
- **Choose Align To Centroid from the Geometry menu**
- **Choose from the sub-menu whether to align one or both axes**

The shapes will be moved as a group to centre their area about the axis origin

## Generating Standard Shapes

Rather than having to draw common structural shapes such as I beams, channels and angles, Section Maker lets you generate such shapes by typing in a few key dimensions.

To generate a standard shape

- **Choose Place Shape from the Shape menu**

A dialog box will appear with a diagram of the shape and its key dimensions

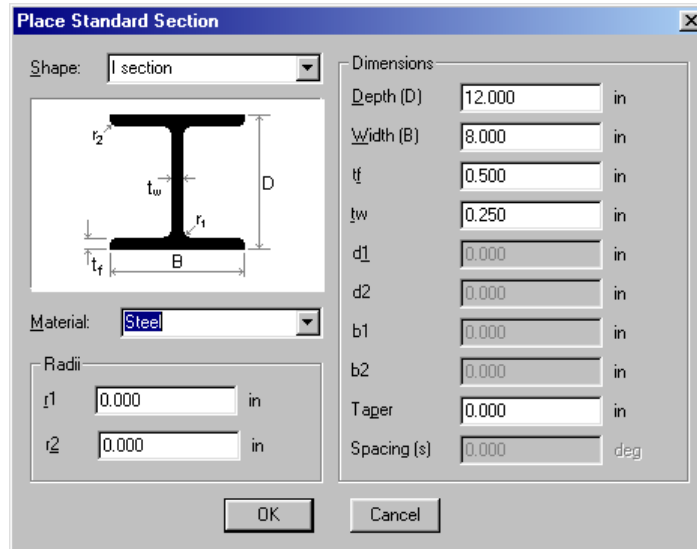

- **Choose the type of shape you wish to generate**
- **Choose a material for the shape**
- **Type in the dimensions of the shape**
- **Click the OK button**

The generated shape will be placed in the Shape window centred about the origin of the x-y axes.

## Fillets and Toes

If you enter non-zero values for the fillet and/or toe radii,  $r_1$  and  $r_2$ , these radii will be modelled as small polygons in the placed shape. This improves the calculation of section properties so that the computed values compare very closely to values published by manufacturers. The radii of the fillet and toes are also stored in section property fields  $r_1$  and  $r_2$  in the sections library.

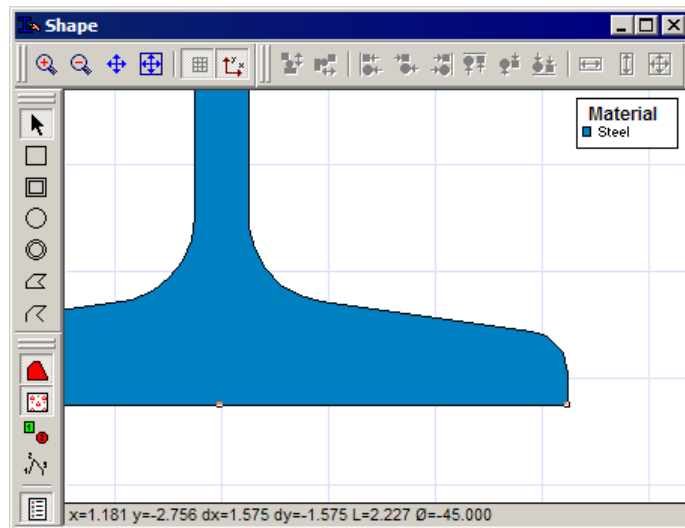

## Using Existing Sections

If you want to create a section, which is made up from other sections, you can place the existing sections using the Place Section command from the Shape menu. You can place standard sections from the Sections Library as well as sections you have drawn and stored previously.

To place a section

- **Choose Place Section from the Shape menu**

A dialog box will appear allowing you to pick the section you wish to place

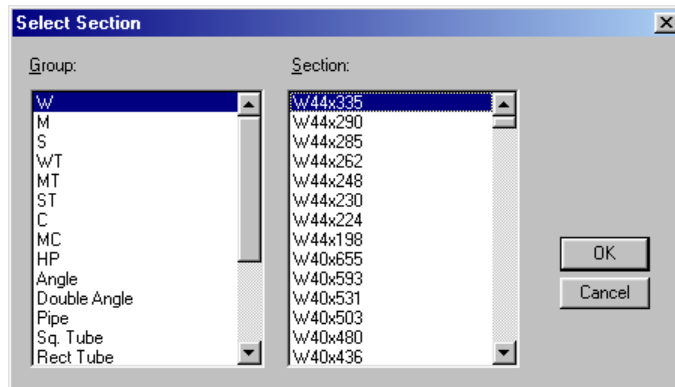

- **Click on the group and section name of the required section**
- **Click the OK button**

The chosen section will be placed in the Shape window.

## Importing a Shape

If you have a shape in another CAD system you can import it into Section Maker by way of a DXF file.

- **Choose Import DXF from the File menu**

The standard file dialog will appear and you can choose the DXF file.

Section Maker will extract all the rectangles, circles and polygons from the DXF file and place them in the Shape window. If there are lines in the DXF file which form a polygonal shape, Section Maker will joint them together at the ends during the import process.

Note that Section Maker does not support the import of arcs within polylines in DXF files. You should explode the polyline in your CAD system before importing. Also make sure to check that the units setting in your cad system matches the units in Section Maker's import dialog. Lastly, ensure that the origin of your coordinate system in your CAD system matches the x-y origin in Section Maker.

## Setting Materials

---

To enable Multiframe to calculate deflections in structures, values for Young's Modulus and Shear Modulus need to be stored with sections in the Sections Library. Section Maker takes these values from the materials you choose for the various shapes, which make up a section. Section Maker allows you to use a number of different materials within the one section. Materials are stored in the Sections Library, standard steel and concrete data is included and you can add your own custom materials to the library.

If you do not assign a material to a shape, Section Maker will assume the shape is a hole and will deduct its properties from the overall properties of the section. Shapes, which are holes, will have negative properties displayed in the Data window.

When shapes you have drawn lie inside each other, you may find it difficult to see which is which, especially when the material patterns are displayed in the shapes. You can control the order in which the shapes are displayed by using the commands under the Arrange sub-menu under the Geometry menu.

To move the selected shapes to the front of all the others

- **Choose Move To Front from the Arrange menu**

To send the select shapes behind all the others

- **Choose Move To Back from the Arrange menu**

To move the selected shapes just in front of the ones currently in front of them

- **Choose Move Forwards from the Arrange menu**

To move the selected shapes just behind the shapes behind it

- **Choose Move Backwards from the Arrange menu**

Note that shapes can be contained inside other shape e.g. steel bar inside a concrete beam or a void inside a beam but shapes cannot overlap partially. See Overlapping Shapes in Chapter 4 for more information.

## Setting Material Types

---

To set the material type of a shape

- **Select the shape**
- **Choose Material from the Shape menu**

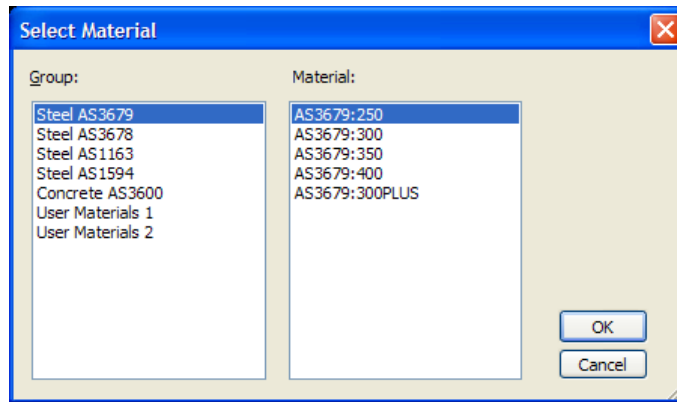

- **Click on the name of the material you require**
- **Click the OK button**

See "Adding a Material" below for information on how to add materials to the library.

### **Advanced Property Calculations**

---

For non standard sections Section Maker uses a finite element technique to accurately compute the torsion constant, warping constant and the location of the shear centre for the section.

The calculation of section properties using this technique requires the shape to be analysed. This is performed by executing the Advanced Calculations command from the Analyse Shape submenu in the Shape menu.

- **Choose Shape | Analyse shape | Advanced calculations**

Upon executing this command the software will automatically mesh the shape drawn in the Shape window and perform a finite element analysis of the section to determine the torsion constant, warping constant and the location of the shear centre.

The accuracy of these properties is reflected in the size of the elements in the finite element mesh. More accurate results may be obtained by refining the mesh size via the Mesh Size command in the Analyse Shape submenu.

- **Choose Shape | Analyse shape | Mesh size**

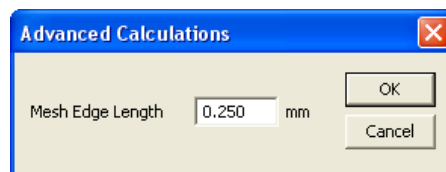

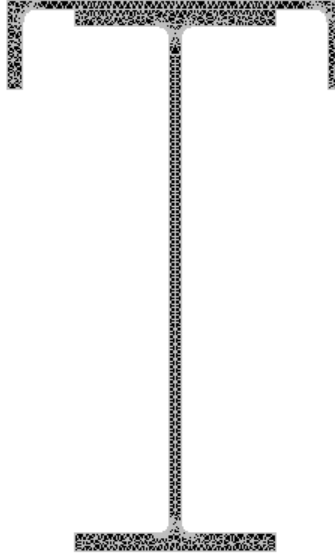

The display of the finite element mesh can be controlled via the Toggle mesh command in the Analyse Shape submenu.

## Viewing Properties

When you draw a shape and specify its material properties, as each change is made the sectional properties are automatically recalculated and displayed in the Properties window

	Property	Value	Units
1	Mass	13.170	lb/ft
2	A	3.870	in <sup>2</sup>
3	I1	8.728	in <sup>4</sup>
4	I2	2.326	in <sup>4</sup>
5	J	0.378	in <sup>4</sup>
6	Z1t	3.086	in <sup>3</sup>
7	Z1b	3.086	in <sup>3</sup>
8	Z2l	1.596	in <sup>3</sup>
9	Z2r	1.417	in <sup>3</sup>
10	r1	1.502	in
11	r2	0.775	in
12	S1	4.958	in <sup>3</sup>
13	S2	2.593	in <sup>3</sup>
14	lw	0.000	10 <sup>6</sup> in <sup>6</sup>
15	Shape	Equal Angle	

The last row in most of the tables shown in the Properties Window displays the Standard Section shape that Section Maker has determined is displayed in the Shape Window. This shape is used as the basis for estimating some of the section properties of the sections. See Chapter 4 for further details on how Section Maker computes section properties.

If you see properties that are displayed in red it means that the shape drawn in the Shape Window is not properly constructed and the section properties have not been computed correctly. See the Validating the Shape section that follows this section for the rules required to ensure the section properties will be computed correctly.

## **Validating the Shape**

---

For Section Maker to correctly evaluate the section properties of the shapes drawn in the Shape Window it is necessary for the geometry of the shape to satisfy the following criteria.

- 1) A shape cannot be hidden by another shape that is drawn in front of it. If a shape is obscured it will be flagged as invalid and ignored when computing the properties of the section drawn in the Shape window.
- 2) A shape can only intersect one other shape. Further, one of these shapes must contain the other.

When the shapes drawn in the Shape Window do not meet the above criteria, the values of the section properties displayed in the Property Window will be displayed in red. Furthermore, any individual shapes that are identified as failing the criteria will be shown in red in the Sections table in the Data Window.

Further information about why the section drawn in the Shape Window is invalid can be determined using the Validate command. To validate a shape

➤ **Choose Validate from the Shape menu**

If the section is invalid, one or more messages will be displayed to the user that identify the invalid geometry within the section. Furthermore, if any invalid shapes are detected, the selection in the Shape Window will be cleared and the invalid shapes will be selected.

In general it is only necessary to use the Validate command if the section properties in the Properties Window are displayed in red.

## **Adding a Section to the Library**

---

Once you have drawn a section to your satisfaction, you can install it into the Sections Library for later use by Multiframe or Section Maker.

To install your section

➤ **Choose Add to Library... from the Shape menu**

A dialog box will appear which lets you specify where the section will be stored, a field for the name of the section, a table with the calculated section properties and a pop-up menu to indicate the shape of the section.

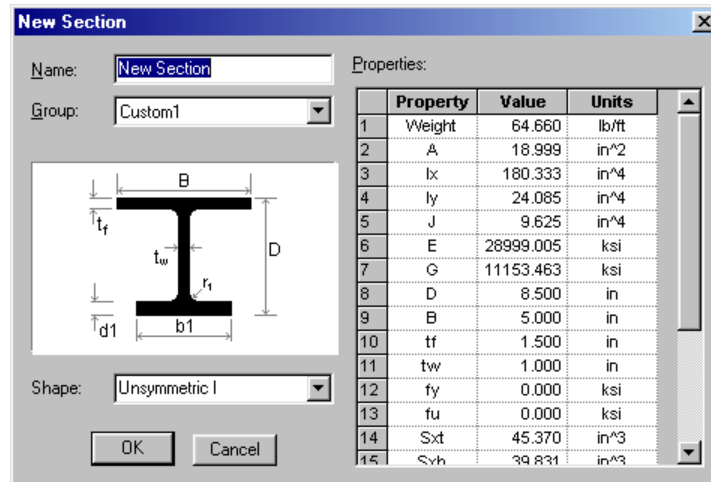

- **Type in a name for the section**
- **Choose the name of the group where you want to store the section**
- **Choose a shape for the section (or just leave it set to unknown)**
- **If you wish you can change the sections properties to override the ones that have been calculated for you. Click on the number to be changed and type in a new value.**
- **Click the OK button**

The section will be stored in the library in the group you have nominated. Note that the library with the new section included will not be saved permanently on the disk until you choose Save Library from the File menu.

If you have Multiframe running, you can now choose Save Library, then switch to Multiframe and choose Open Library->Sections Library from the File menu to reload the library into Multiframe. This will make the section you have added available for use in Multiframe.

## Symbols

---

The content of the Shape Window can be modified to annotate shapes with labels, display dimensions and axes and to control how the shapes are displayed.

### Shape Numbers

---

Each shape in the Shape window can be labelled with its number. To turn on or off the display of the shape numbers

- **Choose Shape Numbers from the Symbols submenu under the Display menu, or**
- **Click the Shape Numbers button on the Symbols toolbar**

### Polyline Numbers

---

Each point along a polyline can be labelled with its index which identifies its positions within the polyline. To turn on or off the display of the polyline numbers

- **Choose Polyline Numbers from the Symbols submenu under the Display menu, or**
- **Click the Polyline Numbers button on the Symbols toolbar**

### **Dimensions**

---

The overall height and width of the section drawn in the Shape Window can be drawn as dimensions. Similarly, the location of the shapes centroid can also be displayed as dimensions. To turn on or off the display of the overall size of the section in the Shape Window

- **Choose Overall Dimensions from the Symbols submenu under the Display menu**

Or, to turn on or off the display of the centroids location

- **Choose Interior Dimensions from the Symbols submenu under the Display menu**

### **Principal Axes**

---

The principal axes of the shape also be displayed in the Shape Window. To turn on or off the display of the principal axes

- **Choose Principal Axes from the Symbols submenu under the Display menu**

### **Axes**

---

The origin of the x-y axis system, which represents the location about which the section properties are computed, may also be displayed in the Shape Window. To turn on or off the display of the these axes

- **Choose Axes from the Symbols submenu under the Display menu**

These axes are displayed by default.

### **Fill**

---

Shapes within the Shape Window can be represented as either the outline of the shape or as a solid object drawn filled. To turn on or off the display of shapes as filled objects

- **Choose Fill from the Symbols submenu under the Display menu**

When shapes are displayed as filled, the outline of the shapes will be displayed in black and the fill colour determine by the colour scheme selected by the user (See the section on Colours which follows). Any shapes that have not been allocated a material and represent a hole will not be filled and will be drawn using a black outline only.

When shapes are displayed as outlines without any fill, the colour of a shapes outline will be determined from the current colour scheme specified by the user.

### **Material Patterns**

---

When shapes are displayed with fill the user has the option of using the pattern associated with the shapes material to draw the interior of the shape. To turn on or off the display of material patterns

- **Choose Material Patterns from the Symbols submenu under the Display menu**

## Legend

---

A legend can be displayed that explains the meaning of each colour used to draw shapes in the Shape Window. The location and style of the legend can be adjusted using the commands in the Legend submenu.

To turn on or off the display of a legend within the Shape Window.

- **Choose Visible from the Legend submenu under the Display menu, or**
- **Click the Legend button on the Symbols toolbar**

Note that for most colour schemes the contents of the legend is dynamic as will reflect only the colour used within the Shape Window. In such cases a legend will not be visible until colour has been used.

## Selecting Shapes

---

A feature of the legend is that it can be used to select all the shapes that correspond to a particular menu item. To set the selection to all the shapes corresponding to a particular legend item simply double click on the text within the legend associated with that item. Holding down shift or control while double clicking on the legend item will extend the current selection.

## Position

---

The position of the legend can be set to any corner of the Shape Window. To display the legend in the bottom right hand corner of the window

- **Choose Bottom Right from the Legend submenu under the Display menu, or**
- **Right click on the legend and choose Bottom Right from the popup menu**

A similar procedure can be followed to display the legend in any corner of the screen using the commands in the Legend submenu.

## Title Font

---

The style of the font used to draw the title of the legend can be set by the used. To modify the style of the title font

- **Choose Title Font from the Legend submenu under the Display menu, or**
- **Right click on the legend and chose Title Font from the popup menu**

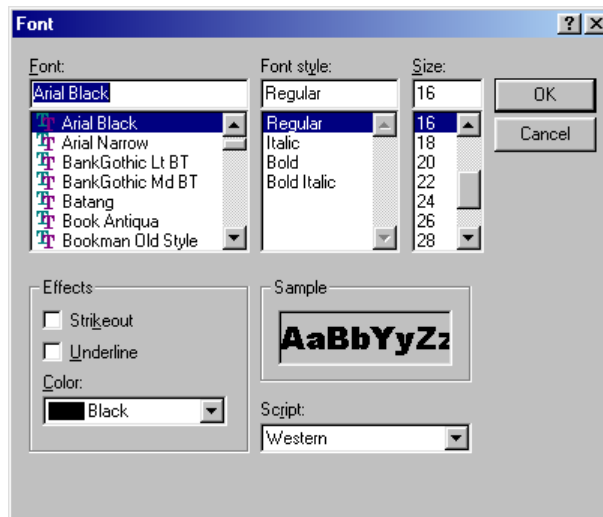

- Specify the required colour style in the Font dialog.
- Click OK

### Font

---

The style of the font used to draw the text of each item in the legend can be set by the used. To modify the style of this font

- Choose Font from the Legend submenu under the Display menu, or
- Right click on the legend and chose Font from the popup menu

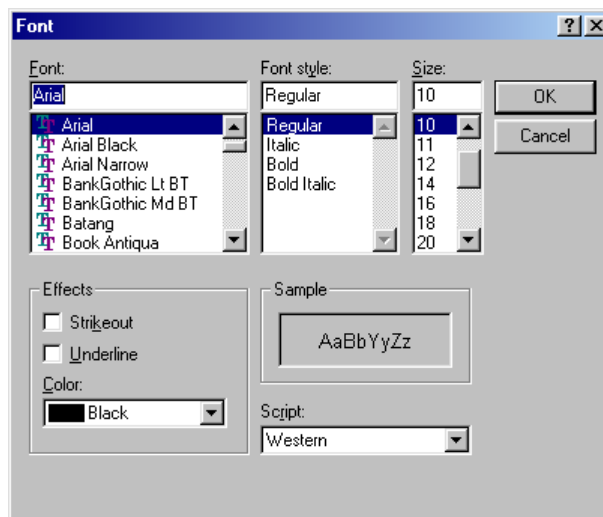

- Specify the required colour style in the Font dialog.
- Click OK

Note that the same colour is used to draw both the item text and the title. Changing the colour of either font will change the colour of the other text.

## Colours

The user can modify the colour corresponding to a particular item in the legend. To modify the colours associated with an items in the legend

- **Choose Item Colour from the Legend submenu under the Display menu, or**
- **Right click on the legend and chose Item Colour from the popup menu**

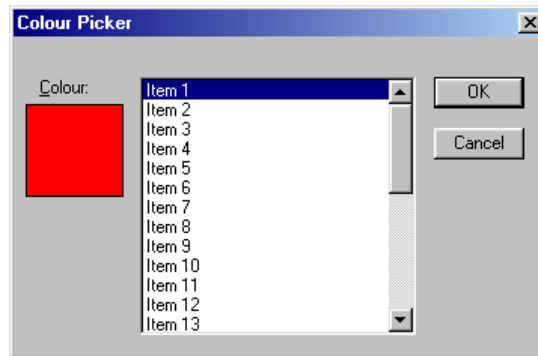

or

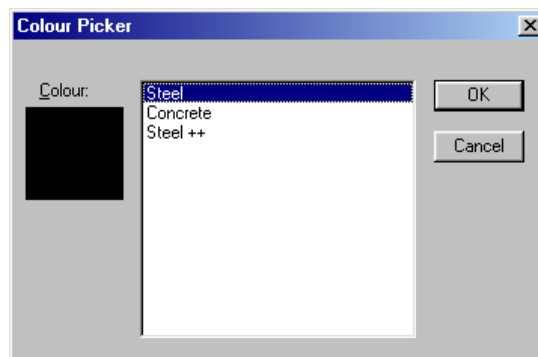

- **Select the legend item to be modified**
- **To change the colour of the selected item, click on the Colour box in the top left hand corner**

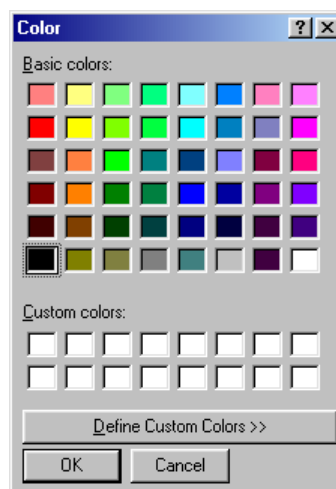

- **Choose a new colour from the Colour dialog**
- **Click OK**

The colour of a particular legend item can also be modified by double clicking of the colour box associated with that item in the legend.

## Chapter 5

# Sections Library Management

---

This chapter describes the use of all of the commands available in Section Maker that are related to the management of sections libraries. It contains a number of sections –

- [Working with Libraries](#)
- [Working with Sections](#)
- [Working with Groups](#)
- [Working with Groups of Materials](#)

Section Maker allows you to add, delete and modify the groups of materials stored in a sections library.

In this section:

- [Viewing Groups](#)
- [Locking/Unlocking a Group](#)
- [Adding a Sections Group](#)
- [Editing a Sections Group](#)
- [Duplicating a Group](#)
- [Deleting a Group](#)
- [Reordering Groups](#)

Please note that all the commands described in this section are only available when you have the Materials window activated. Some of the command swill only be available when the Groups tab is activated within this window.

### Viewing Material Groups

---

The groups of materials stored in the Library can be viewed and changed in the Groups tab within Materials Window of Section Maker. A list of all the groups of material within the library is displayed in the Groups tab within this window.

To make the Groups Table visible

- **Choose Materials from the Window menu**
- **Click on the Groups tab in the navigation bar at the bottom of the window.**

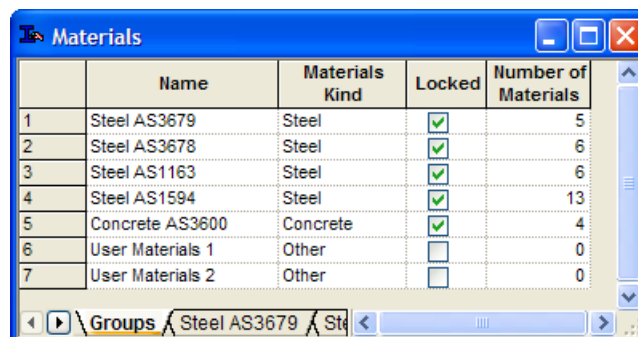

### **Locking/Unlocking a Group of Materials**

---

Groups are locked using a checkbox in the “Locked” column in the Groups tab in the Materials Window. To unlock a group, clear the checkbox in the “Locked” column of the Groups tab in the Materials window. Groups can also be locked/unlocked via the Group Properties dialog.

### **Adding a Materials Group**

---

Material Maker allows you to add groups to or remove groups from the library you currently have open. This makes it more convenient for you to choose materials. If there are groups in the library you never use you could remove them or if there is a table of custom materials you often use you could add them in a separate group in the library.

To Add a Materials Group to the Library

- **Choose Add Materials Group from the Materials submenu under the Library menu**

A dialog box will appear with a field for the group's name, a table showing where key properties will be stored in the group, a text box for the number of fields of data to be stored with each material in the group and a pop-up menu to indicate the shape of materials in the group.

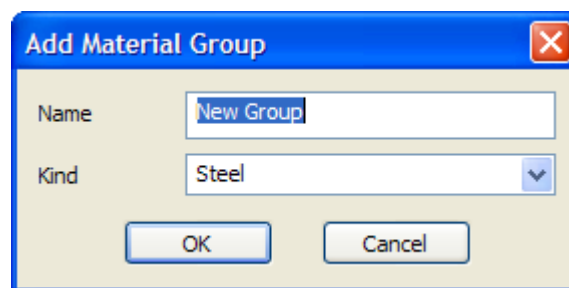

- **Type in a name for the group**
- **Choose the kind of materials to be stored in this group**

If you have more than one kind of shape or the shape is not one of the standard shapes, leave the shape set to the Unknown Material value.

- **Click the OK button**

The group will be added to the library and will display in the Materials Window.

### **Editing a Materials Group**

---

The properties of material groups are edited via the Group table in the Materials Window. To edit the properties of a material group in the current sections library

- **Click on the Group tab in the list a tabs in the bottom corner of the Materials Window.**

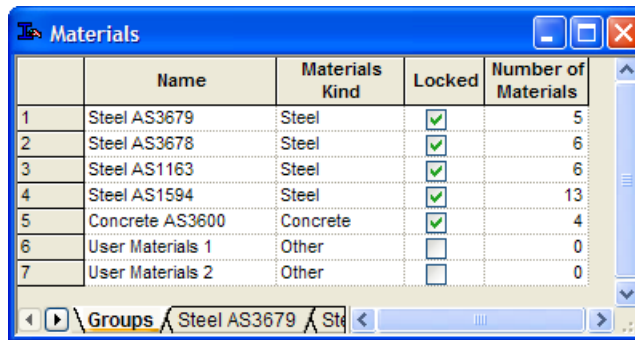

	Name	Materials Kind	Locked	Number of Materials
1	Steel AS3679	Steel	<input checked="" type="checkbox"/>	5
2	Steel AS3678	Steel	<input checked="" type="checkbox"/>	6
3	Steel AS1163	Steel	<input checked="" type="checkbox"/>	6
4	Steel AS1594	Steel	<input checked="" type="checkbox"/>	13
5	Concrete AS3600	Concrete	<input checked="" type="checkbox"/>	4
6	User Materials 1	Other	<input type="checkbox"/>	0
7	User Materials 2	Other	<input type="checkbox"/>	0

The name and kind can be edited directly with the table.

### Duplicating a Group of Materials

To duplicate a group from the Materials Library

- **Choose Duplicate Material Group from the Materials submenu under the Library menu**

A copy of the current group, including all materials contained within the group, will be added to the end of library and made the current group on display in the Materials Window.

### Deleting a Group

To remove a group from the Materials Library

- **Choose Delete Material Group from the Materials submenu under the Library menu**

A list of the groups in the library will be displayed

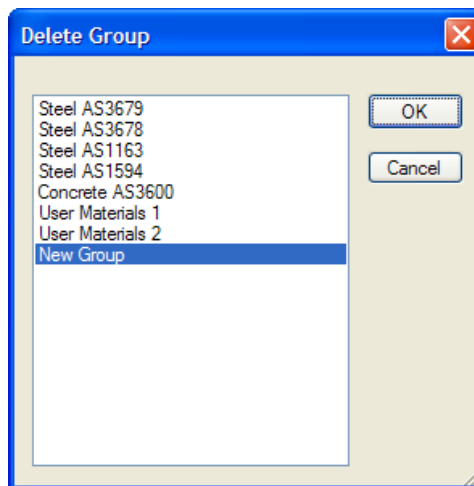

- **Click on the group to be removed**

If you wish to remove more than one group, hold down the shift key while clicking on the names of the other groups

- **Click the OK button**

The groups selected and all the materials stored in them will be removed from the library.

### Reordering Groups

---

The order in which groups appear within the materials library can be modified. To change the order of groups within the materials library

- **Choose Reorder Material Groups from the Materials submenu under the Library menu**

A list of the groups in the library will be displayed

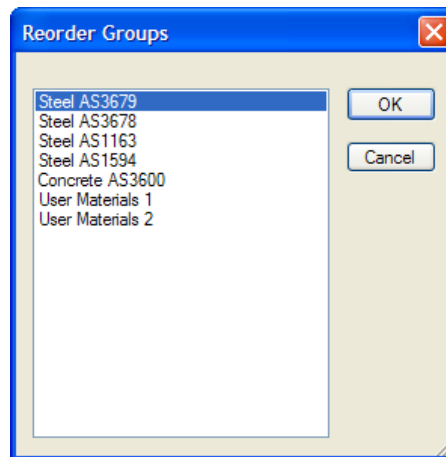

- **Click on the group to be moved, keeping the mouse button depressed**
- **Drag the cursor to locate the new position for the group and release the mouse button.**

If you wish to move than one group then simply repeat the above two steps for each group to be moved to a new position within the library.

- **Click the OK button**

The new ordering of groups will be saved to the library.

- **Working with Materials**

### Working with Libraries

---

As well as enabling you to draw and add individual sections to the library, Section Maker has a number of features that make it easier for you to manage your sections library. You can add and remove groups of sections or materials from the library, add or remove a large number of sections at once, add, edit or remove materials from the library..

You can change the contents of the library via the Sections or Materials Windows that tabulate the properties of all the sections and materials stored in the library. In the Sections Window, each group of sections is displayed in a separate tab. Each tab displays a table in which you can view and change any of the section properties. The Sections Window also contains a Group tab which lists all the groups of sections contained in the library and their properties. The Material Window contains a number of tables listing the properties of all the materials in the library. This window contains separate tabs for each of the material groups in the library as well as a tab listing the groups of materials and the properties of those groups.

You can also create completely new libraries or read, modify and write any number of sections libraries. This means you can keep a number of libraries on your disk and use them for different applications.

In this section:

- [Fields and Section Properties](#)
- [Creating a New Library](#)
- [Opening a Library](#)
- [Saving a Library](#)
- [Saving as Text](#)
- [Group Organiser](#)

### **Fields and Section Properties**

---

The concept central to the structure of the sections library is that the section property data associated with a group of sections should reflect the data tables published by manufacturers or industry organisations. With this in mind the data displayed in the sections table in the Sections Window should reflect the published section properties. Each column of data in this table represents a *field*. In order to utilise this data in Multiframe it is necessary to identify which section property that a field represents. For some types of sections, typically symmetric sections, several section properties may be mapped to the same field. For example if  $I_x=I_y$  then there is only a need for a single  $I$  field. In addition, a factor must be specified with each field to convert the value in the field to the base units of newtons, metres and kilograms.

### **Creating a New Library**

---

Section Maker allows you to create a new library for use with any of the Multiframe applications. All you have to do to make the new library the default is to place it in the same folder as the application and name it "SectionsLibrary.slb". If you already have a sections library in the folder with that name, rename the existing library to a different name and then name your new library "SectionsLibrary.slb".

To create a new library

- **Choose New Library from the File menu**

A new library will be created with no groups or sections. You can add groups and sections to the library (see Adding a Group and Adding a Section below) before saving it to disk with the Save As command from the File menu.

### **Opening a Library**

---

You do not have to work with the sections library that automatically opens when Section Maker starts up. (If Section Maker finds a library named SectionsLibrary.slb in the same folder as Section Maker, it will automatically open it on start-up) If you wish you can open any other library and work with it in the normal way.

To open a sections library

- **Choose Open Library from the File menu**

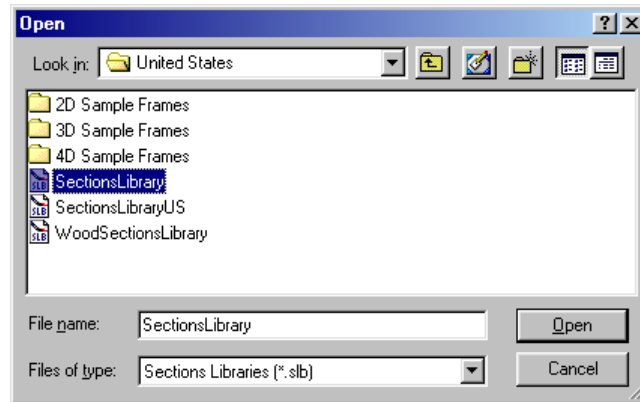

- **Click on the name of the library you wish to open**
- **Click the Open button**

The contents of the library will be read in and the groups, materials and sections in the library will be displayed in the tables within the Sections and Materials Windows respectively.

### **Saving a Library**

---

If you have installed any sections in the library or you have changed the section or group properties in any way, you will have to save the Sections Library to disk to make the changes permanent.

To save the Sections Library to disk

- **Choose Save Library from the File menu**

To save the Sections Library to disk with a new name

- **Choose Save As from the File menu**
- **Select the folder or disk where you will save the library**
- **Type in a name for the library**
- **Click the Save button**

### **Saving as Text**

---

Another way to view the data in the library is to save it in text format. Text files can be read into a word processor or you could write your own software which extracts data from a text file of sections.

To save the contents of the library in a text file

- **Choose Export -> Text File from the File menu**
- **Type in a name for the text file of data**
- **Choose which disk or folder you want to store the data in**
- **Click the Save button**

The complete contents of the sections library will be saved to disk in a text file. The format of this file is documented in Chapter 4.

### Group Organiser

Groups of sections or materials may be copied between libraries using the Group Organiser. The Group Organiser may also be used to delete groups from a sections library. The Group Organiser dialog (shown below) provides this functionality by opening two sections libraries. The groups of section and materials in these libraries are listed on either side of the dialog. Groups can be copied between the libraries by selecting the group(s) to be copied and clicking the Copy button. Similarly, groups may be deleted from a library by selecting the groups to be deleted and clicking the Remove Selected Groups button.

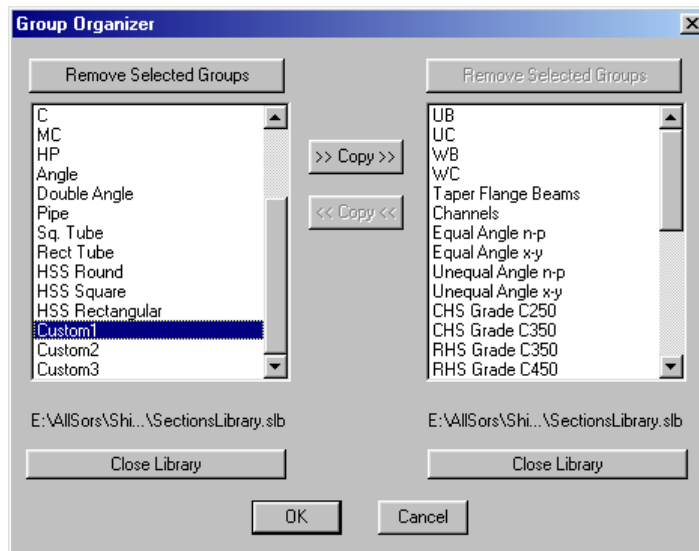

Any two libraries may be displayed in the Group Organiser dialog. By default, one of these libraries is set to the current sections library when the Group Organiser is first opened.

To import a group of sections or materials from another sections library into the library currently opened by Section Maker

- **Choose Group Organiser... from the Library menu**

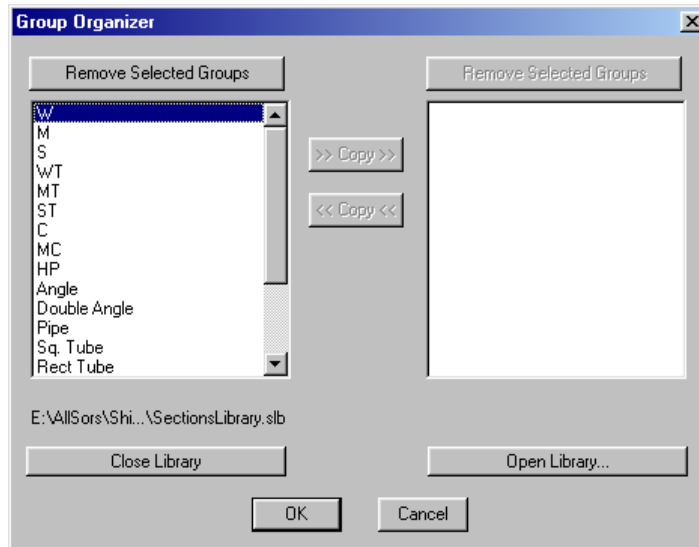

The current library is already open in the dialog and displayed down the left hand side.

- **Click the Open Library... button on the right hand side of the dialog.**
- **Using the resulting file dialog, choose the sections library from which to import the group of sections.**

This library will be displayed on the right hand side of the Group Organiser dialog.

- **Select the group(s) to be imported to the current library from the right hand list of groups.**
- **Click the <<Copy<< button.**
- **Click the left hand Close Library button**

This will save the current library

- **Click the OK button.**

## **Working with Groups of Sections**

Section Maker allows you to add, delete and modify the groups of sections stored in a sections library.

In this section:

- [Viewing Groups](#)
- [Locking/Unlocking a Group](#)
- [Adding a Sections Group](#)
- [Editing a Sections Group](#)
- [Duplicating a Group](#)
- [Deleting a Group](#)
- [Reordering Groups](#)
- [Adding a Field](#)
- [Editing Fields](#)
- [Deleting a Field](#)
- [Reordering Fields](#)

Please note that all the commands described in this section are only available when you have the Sections window activated. Some of the command will only be available when the Groups tab is activated within this window.

### Viewing Groups

The groups stored in the Library can be viewed and changed in the Groups tab within Sections Window of Section Maker. A list of all the groups of section within the library is displayed in the Groups tab within this window.

To make the Groups Table visible

- **Choose Sections from the Window menu**
- **Click on the Groups tab in the navigation bar at the bottom of the window.**

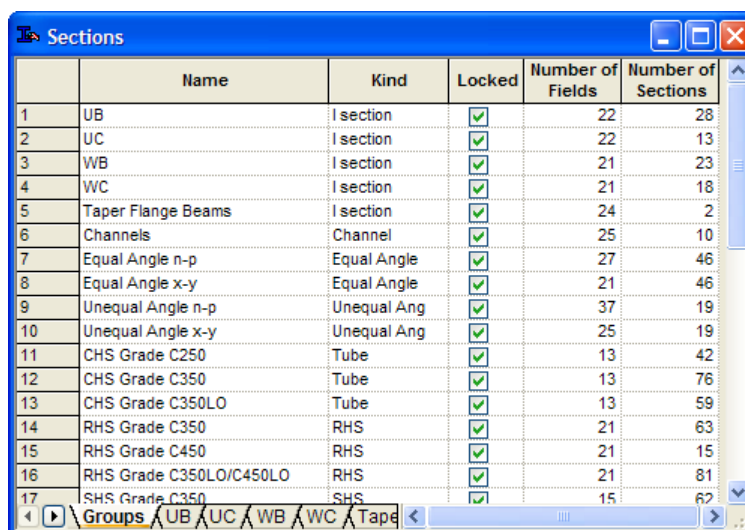

	Name	Kind	Locked	Number of Fields	Number of Sections
1	UB	I section	<input checked="" type="checkbox"/>	22	28
2	UC	I section	<input checked="" type="checkbox"/>	22	13
3	WB	I section	<input checked="" type="checkbox"/>	21	23
4	WC	I section	<input checked="" type="checkbox"/>	21	18
5	Taper Flange Beams	I section	<input checked="" type="checkbox"/>	24	2
6	Channels	Channel	<input checked="" type="checkbox"/>	25	10
7	Equal Angle n-p	Equal Angle	<input checked="" type="checkbox"/>	27	46
8	Equal Angle x-y	Equal Angle	<input checked="" type="checkbox"/>	21	46
9	Unequal Angle n-p	Unequal Ang	<input checked="" type="checkbox"/>	37	19
10	Unequal Angle x-y	Unequal Ang	<input checked="" type="checkbox"/>	25	19
11	CHS Grade C250	Tube	<input checked="" type="checkbox"/>	13	42
12	CHS Grade C350	Tube	<input checked="" type="checkbox"/>	13	76
13	CHS Grade C350LO	Tube	<input checked="" type="checkbox"/>	13	59
14	RHS Grade C350	RHS	<input checked="" type="checkbox"/>	21	63
15	RHS Grade C450	RHS	<input checked="" type="checkbox"/>	21	15
16	RHS Grade C350LO/C450LO	RHS	<input checked="" type="checkbox"/>	21	81
17	RHS Grade C350	RHS	<input checked="" type="checkbox"/>	15	62

### Locking/Unlocking a Group of Sections

Groups are locked using a checkbox in the “Locked” column in the Groups tab in the Sections Window. To unlock a group, clear the checkbox in the “Locked” column of the Groups tab in the Sections window. Groups can also be locked/unlocked via the Group Properties dialog.

### Adding a Sections Group

Section Maker allows you to add groups to or remove groups from the library you currently have open. This makes it more convenient for you to choose sections. If there are groups in the library you never use you could remove them or if there is a table of custom sections you often use you could add them in a separate group in the library.

To Add a Sections Group to the Library

- **Choose Add Sections Group from the Sections submenu under the Library menu**

A dialog box will appear with a field for the group's name, a table showing where key properties will be stored in the group, a text box for the number of fields of data to be stored with each section in the group and a pop-up menu to indicate the shape of sections in the group.

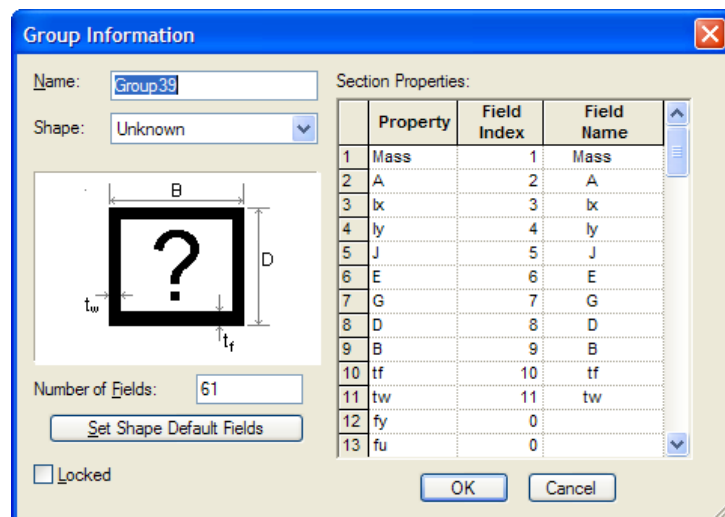

- **Type in a name for the group**
- **Choose from the Shape list the kind of shapes stored in this group**

If you have more than one kind of shape or the shape is not one of the standard shapes, leave the shape set to the Unknown Section value.

- **Click the Set Shape Default Fields button.**

This will set up a default number of fields that represent the information required for the shape of section selected in the step above.

If you wish you could type in the number of fields you require. If you do add extra fields, you can type a number next to each of the key properties to tell Multiframe in which field that property will be stored. For example the first line of the table indicates that the mass per unit length of the section is stored in a field named Mass and this is the first field of the group. If you do change any of these values it is very important that you keep the naming and units for the property consistent and always store the property in the field indicated. Multiframe relies on this information to do analysis and if you make an error entering the key properties, the results of analysis may be incorrect. If in doubt, leave the group with the standard fields and properties.

➤ **Click the OK button**

The group will be added to the library and will display in the Sections Window.

### Editing a Sections Group

To edit the properties of a Group in the current sections library

➤ **Choose Section Group Properties from the Sections submenu under the Library menu**

A dialog box will appear with a field for the group's name, a table showing where key properties will be stored in the group, a text box for the number of fields of data to be stored with each section in the group and a pop-up menu to indicate the shape of sections in the group.

	Property	Field Index	Field Name
1	Mass	1	Mass
2	A	7	A
3	bx	8	bx
4	ly	11	ly
5	J	14	J
6	E	15	E
7	G	16	G
8	D	2	D
9	B	3	B
10	tf	4	tf
11	tw	5	tw
12	fy	0	
13	fu	0	

The table displays the mapping of section properties to data fields. The first column named Property shows the internal Multiframe property contained in the file. The second column named Field Index indicates which field in the group this property can be found in. This column can contain a zero if the group does not contain that property. The final column Field Name will be updated when you change the Field Index to let you know which field in the group is being referred to. IN fact it is easier to change the Field Name column via the drop down menu in the cell, and the Field Index will be updated for you.

If you do change any of the values in this table, it is very important that you keep the naming and units for the property consistent and always store the property in the field indicated. Multiframe relies on this information to do analysis and if you make an error entering the key properties, the results of analysis may be incorrect. If in doubt, leave the group with the standard fields and properties.

- **Click the OK button**

### **Duplicating a Group of Sections**

---

To duplicate a group from the Sections Library

- **Choose Duplicate Section Group from the Sections submenu under the Library menu**

A copy of the current group, including all sections contained within the group, will be added to the end of library and made the current group on display in the Sections Window.

### **Deleting a Group**

---

To remove a group from the Sections Library

- **Choose Delete Section Group from the Sections submenu under the Library menu**

A list of the groups in the library will be displayed

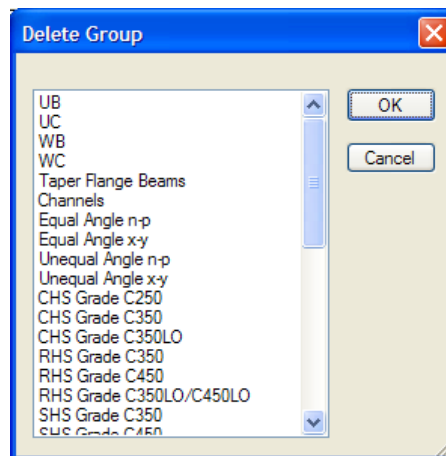

- **Click on the group to be removed**

If you wish to remove more than one group, hold down the shift key while clicking on the names of the other groups

- **Click the OK button**

The groups selected and all the sections stored in them will be removed from the library.

### **Reordering Groups**

---

The order in which groups appear within the sections library can be modified. To change the order of groups within the sections library

- **Choose Reorder Section Groups from the Sections submenu under the Library menu**

A list of the groups in the library will be displayed



- **Type in the name of the new field**
- **Select the section properties that will correspond to the new field.**
- **Select the units for the new field.**
- **Click the OK button.**

The additional fields will be displayed in the Groups Table in the Sections window and additional columns will be added to the Sections table in the Section Window.

### Editing Fields

You can change the information about fields in the Groups Tables in the Sections Window. To change the name of the field, click on its current name, type in a new name and press the enter key.

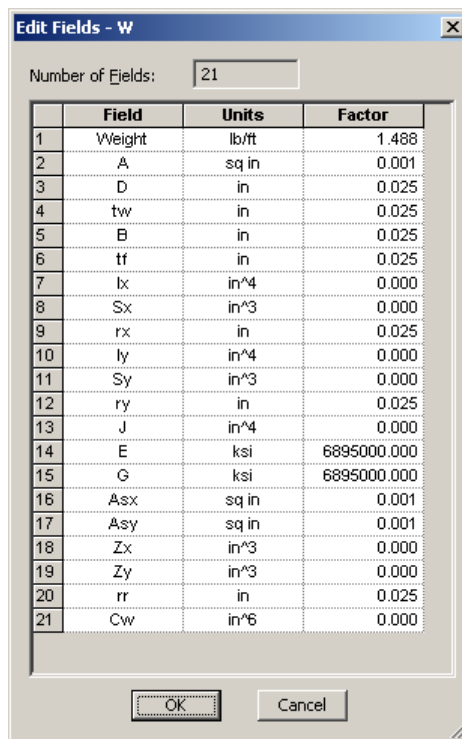

The units for the field may also be modified. In the units column, type in the name of the units you want to use to store properties in this field. For example, if you added a field named Iw for a warping constant your units might be in<sup>6</sup> (inches to the sixth power) so you should type this into the units column. You should also type in a factor to convert the fields values into Section Maker's internal units system. This will allow you or another user to change units and still have the properties displayed correctly. The factor is the number the entered value must be multiplied by to convert it into a Newton, meter, kilogram units system. i.e. in the case where Iw will be entered in units of in<sup>6</sup>, the factor will be 6.820907E-12 (i.e. 1/39.37 to the power of six as there are 39.37 inches in a meter)

Some common units factors are

Name	Property	Metric	Factor	English	Factor
		Unit		Unit	

Mass	Mass per unit length	kg/m	1.0	lb/ft	1.488
A, Asx, Asy	Cross sectional area	mm <sup>2</sup>	1E-6	in <sup>2</sup>	6.452E-4
Ix	Major moment of inertia	mm <sup>4</sup>	1E-12	in <sup>4</sup>	1.638E-5
Iy	Minor moment of inertia	mm <sup>4</sup>	1E-12	in <sup>4</sup>	1.638E-5
J	Torsion constant	mm <sup>4</sup>	1E-12	in <sup>4</sup>	1.638E-5
E	Young's Modulus	MPa	1E-6	ksi	6895000
G	Shear Modulus	MPa	1E-6	ksi	6895000
D	Depth	mm	0.001	in	0.0254
B	Breadth or Width	mm	0.001	in	0.0254
tf	Flange thickness	mm	0.001	in	0.0254
tw	Web thickness	mm	0.001	in	0.0254

### Deleting a Field

You can delete fields that you have added by using the Delete Field command from the Sections submenu under the Library menu.

To delete a field or fields from the current group

- **Choose Delete Field from the Sections submenu under the Library menu**
- **Click in the name of the field to be removed**

If you wish to remove more than one field, shift click on the additional field names

- **Click the OK button**

**WARNING:** Do NOT delete any of first eleven standard fields in a group as Multiframe uses them in its analysis.

### Reordering Fields

The order in which fields are presented for a group can be modified as follows.

- **Choose Reorder Fields from the Sections submenu under the Library menu**

A list of fields within the group will be displayed

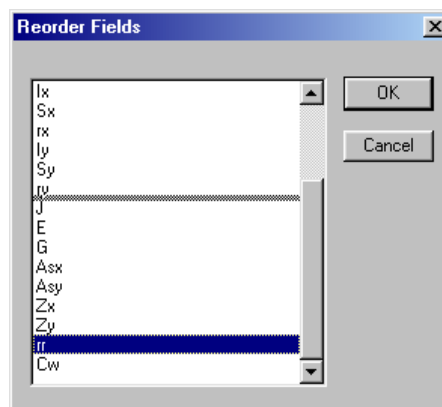

- **Click on the field to be moved, keeping the mouse button depressed**

- **Drag the cursor to locate the new position for the field and release the mouse button.**

If you wish to move than one field then simply repeat the above two steps for each field to be moved to a new position.

- **Click the OK button**

The new ordering of fields will be displayed in the Groups Tables in the Sections Window.

## **Working with Sections**

---

Section Maker allows you to add, delete and modify data associated with each section stored in a sections library.

In this section:

- [Viewing Sections](#)
- [Adding a Section](#)
- [Deleting a Section](#)
- [Changing Section Properties](#)
- [Custom Shape Data](#)
- [Section Colour](#)
- [Reordering Sections](#)
- [Generating Tapered Sections](#)

Please note that all the commands described in this section are only available when you have the a table of sections active in the Sections Window.

### **Viewing Sections**

---

The sections stored in the Sections Library can be viewed and changed in the Sections Window of Section Maker. The sections are displayed, a group at a time, in the Sections Table within this window.

To make the Sections Table visible

- **Choose Library from the Window menu**
- **Click on a tab at the bottom of the window to select the group of sections to be viewed.**

	Name	Colour	Shape	Custom shape data	Material Group	Material Grade	Weight lb/ft	A sq in
1	W44x335		Group - I section	<input type="checkbox"/>	Steel ASTM A	A992	335.000	98.300
2	W44x290		Group - I section	<input type="checkbox"/>	Steel ASTM A	A992	290.000	85.800
3	W44x285		Group - I section	<input type="checkbox"/>	Steel ASTM A	A992	285.000	83.800
4	W44x262		Group - I section	<input type="checkbox"/>	Steel ASTM A	A992	262.000	77.200
5	W44x248		Group - I section	<input type="checkbox"/>	Steel ASTM A	A992	248.000	72.800
6	W44x230		Group - I section	<input type="checkbox"/>	Steel ASTM A	A992	230.000	67.700
7	W44x224		Group - I section	<input type="checkbox"/>	Steel ASTM A	A992	224.000	65.800
8	W44x198		Group - I section	<input type="checkbox"/>	Steel ASTM A	A992	198.000	58.000
9	W40x655		Group - I section	<input type="checkbox"/>	Steel ASTM A	A992	655.000	192.000
10	W40x593		Group - I section	<input type="checkbox"/>	Steel ASTM A	A992	593.000	174.000
11	W40x531		Group - I section	<input type="checkbox"/>	Steel ASTM A	A992	531.000	156.000
12	W40x503		Group - I section	<input type="checkbox"/>	Steel ASTM A	A992	503.000	148.000
13	W40x480		Group - I section	<input type="checkbox"/>	Steel ASTM A	A992	480.000	140.000
14	W40x436		Group - I section	<input type="checkbox"/>	Steel ASTM A	A992	436.000	128.000
15	W40x431		Group - I section	<input type="checkbox"/>	Steel ASTM A	A992	431.000	127.000
16	W40x397		Group - I section	<input type="checkbox"/>	Steel ASTM A	A992	397.000	117.000
17	W40x392		Group - I section	<input type="checkbox"/>	Steel ASTM A	A992	392.000	115.000

### Adding a Section

To add a section or a number of sections to the current group in the library **Select Window | Sections** to bring the Sections window to the front

- Click on the tab at the bottom of this window with the name of the group to which the new sections are to be added.
- Using the **Group Toolbar**, select which group you wish to add a section to.

#### Note

You can only add sections to groups that are unlocked. To unlock a group, see [Locking/Unlocking a Group](#) on page 62.

- Choose **Add Section** from the Sections submenu under the Library menu

A dialog box will appear allowing you to specify how many sections you wish to add.

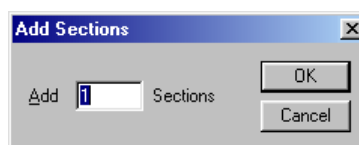

- Type in the number of sections to be added
- Click the OK button

A number of sections titled Section1, Section2 and so on will be added to the current group. They will initially have all their properties set to zero. You can view and edit the added sections in the Section table in the Sections Window.

### Deleting a Section

To remove a section or a number of sections from the library

- Choose **Delete Section** from the Sections submenu under the Library menu

A dialog box will appear with a list of the names of the sections in the current group

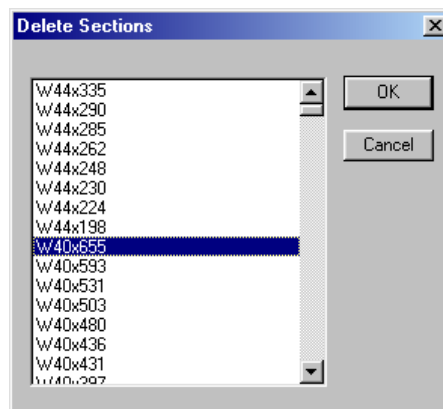

- **Click on the name of the section to be removed**

If you want to remove more than one section, hold down the shift key and click or drag over the additional sections to be removed

- **Click the OK button**

The sections will be removed from the library. Remember that the changes will not be made permanent until you save the library to disk using the Save Library command from the File menu.

### **Changing Section Properties**

---

To change the value of a property stored with a section

- **Click on the property to be changed**
- **Type in a new value**
- **Press the Enter key**

When you change the properties of a section, you must use the units indicated at the top of the column for the property displayed in that column of the table. The standard properties stored in a group are

<b>Name</b>	<b>Property</b>	<b>Metric</b>	<b>English</b>
Mass	Mass per unit length	kg/m	lb/ft
A	Cross sectional area	mm <sup>2</sup>	in <sup>2</sup>
Ix	Major moment of inertia	mm <sup>4</sup>	in <sup>4</sup>
Iy	Minor moment of inertia	mm <sup>4</sup>	in <sup>4</sup>
J	Torsion constant	mm <sup>4</sup>	in <sup>4</sup>
E	Young's Modulus	MPa	ksi
G	Shear Modulus	MPa	ksi
D	Depth	mm	in
B	Breadth or Width	mm	in
tf	Flange thickness	mm	in
tw	Web thickness	mm	in
fy	Yield Strength	MPa	ksi
fu	Ultimate Strength	MPa	ksi
Sxt (or Zxt)	Elastic Modulus about x at top	mm <sup>3</sup>	in <sup>3</sup>
Sxb (or Zxb)	Elastic Modulus about x at bottom	mm <sup>3</sup>	in <sup>3</sup>
Sxt (or Zxt)	Elastic Modulus about x at top	mm <sup>3</sup>	in <sup>3</sup>

<b>Name</b>	<b>Property</b>	<b>Metric</b>	<b>English</b>
Syl (or Zyl)	Elastic Modulus about y at left	mm <sup>3</sup>	in <sup>3</sup>
Syr (or Zyr)	Elastic Modulus about y at right	mm <sup>3</sup>	in <sup>3</sup>
rx	radius of gyration about x	mm	in
ry	radius of gyration about y	mm	in
Sx (or Zx)	Plastic Modulus about x	mm <sup>3</sup>	in <sup>3</sup>
Sy (or Zy)	Plastic Modulus about y	mm <sup>3</sup>	in <sup>3</sup>
Iw	Warping constant	mm <sup>3</sup>	in <sup>3</sup>
rz	radius of gyration about weakest axis	mm	in
Asx	Shear area in weak axis direction (x)	mm <sup>2</sup>	in <sup>2</sup>
Asy	Shear area in strong axis direction (y)	mm <sup>2</sup>	in <sup>2</sup>
b1,b2	Additional width dimensions required for some section shapes. (e.g. Width of Zed flanges)	mm	in
d1,d2	Additional width dimensions required for some section shapes. (e.g. Depth of lip for Cee or Zed sections)	mm	in
b2	Width of bottom Zed flange	mm	in
d1	Depth of lip of Cee or Zed shape	mm	in
D2	Depth of lip of Cee or Zed shape	mm	in
xc, yc	Position of centroid as measured for bottom left hand corner of section	mm	in
Ø	Angle of principle axes from section axes.	degrees	degrees
Iu	Moment of inertia about major principle axis.	mm <sup>4</sup>	in <sup>4</sup>
Iv	Moment of inertia about minor principle axis.	mm <sup>4</sup>	in <sup>4</sup>
Ru	Radius of gyration about major principle axes	mm	in
Rv	Radius of gyration about minor principle axes	mm	in
Sut or Zut	Elastic Modulus about major principle axes in positive v axis direction.	mm <sup>3</sup>	in <sup>3</sup>
Sub or Zub	Elastic Modulus about major principle axes in negative v axis direction.	mm <sup>3</sup>	in <sup>3</sup>
Svt or Zvt	Elastic Modulus about minor principle axes in positive u axis direction.	mm <sup>3</sup>	in <sup>3</sup>
Svb or Zvb	Elastic Modulus about minor principle axes in negative u axis direction.	mm <sup>3</sup>	in <sup>3</sup>
xs, ys	Position of shear centre as measure from centroid.	mm	in
P	Perimeter of section	mm	in
Tan(Ø)	Tan of principle axis angle		
s	Spacing parameter	mm	in
r1	Primary radii (e.g. Fillet radius)	mm	in
r2	Secondary radii (e.g. Toe radius)	mm	in
Ixy	Product of Inertia	mm <sup>4</sup>	in <sup>4</sup>

The following diagram will help you determine the dimensional properties. These properties are used by Multiframe for rendering and display of member details and stresses and by Section Maker for placing standard shapes and existing sections.

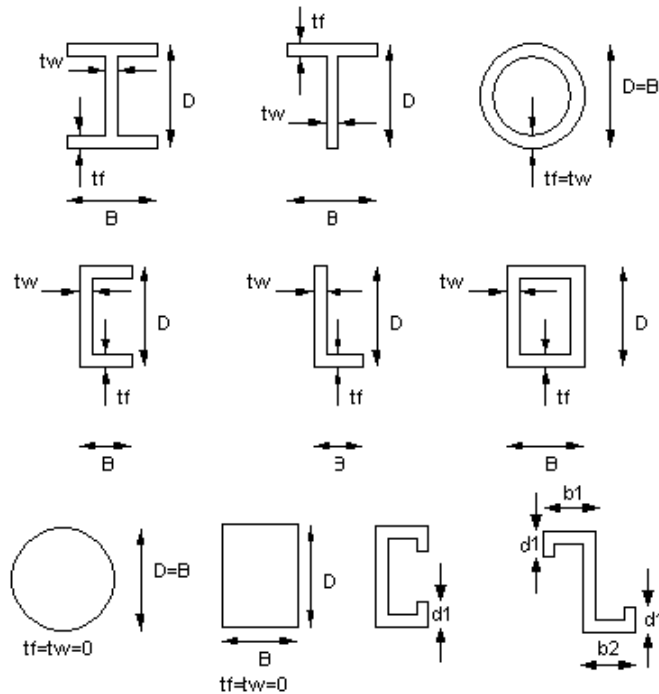

### Custom Shape Data

When a section designed within Section Maker is added to the sections library extra geometric data is stored in the library along with the section properties. This data is used to recreate the geometry of the section within both Section Maker and Multiframe. This data cannot be viewed or edited. Caution should be exercised when cutting and pasting data within the Sections Table so as to not change the order of the sections in this table.

### Section Colour

A colour may be associated with each section in the library. This colour is used by Multiframe when displaying section colours in the Frame Window. In Section Maker, the colour of each section is displayed in the Section Table in the Sections Window.

To change the colour associated with a section

- **View the section properties in the Section Table in the Sections Window**

	Name	Colour	Mass kg/m	D mm	B mm
1	610UB125	Red	125.000	612.000	229.000
2	610UB113	Yellow	113.000	607.000	228.000
3	610UB101	Green	101.000	602.000	228.000
4	530UB92.4	Cyan	92.400	533.000	209.000
5	530UB82.0	Blue	82.000	528.000	209.000
6	460UB82.1	Purple	82.100	460.000	191.000
7	460UB74.6	Pink	74.600	457.000	190.000
8	460UB67.1	Magenta	67.100	454.000	190.000
9	410UB59.7	Orange	59.700	406.000	178.000
10	410UB53.7	Purple	53.700	403.000	178.000
11	360UB56.7	Black	56.700	359.000	172.000

- **Double click on the cell in the Colour column.**

The standard Windows dialog for selecting colours will appear.

- **Click on the new colour for the section**
- **Click the OK button**

Section colours may also be cut and pasted between sections and the Fill Down function may be used to set ranges of sections to the same colour. Remember that the changes will not be made permanent until you save the library. By default all section colours are set to black.

### Reordering Sections

---

The order in which sections appear within a group can be modified as follows.

- **Choose Reorder Sections from the Sections submenu under the Library menu**

A list of fields within the group will be displayed

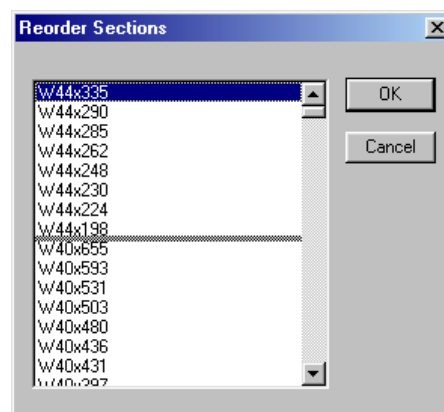

- **Click on the section to be moved, keeping the mouse button depressed**
- **Drag the cursor to locate the new position for the section and release the mouse button.**

If you wish to move than one section then simply repeat the above two steps for each section to be moved to a new position within the group.

- **Click the OK button**

The new ordering of sections will be displayed in the Section Tables in the Sections Window.

### Generating Tapered Sections

---

Section Maker allows you to automatically create a number of sections, which interpolate between two existing sections. This can be used to model the changing sectional shape in a tapered member. Suppose you were modelling a tapered beam in Multiframe that started with a 12inch (300mm) deep section and tapered to a 24inch(600mm) deep section. You could draw the first section and install it in the library, then draw the second section and install it. To create the intermediate sections you use the Taper command from the Shape window.

To install a number of intermediate sections between to existing sections

- **Choose Generate Tapered Sections... from the Library | Sections submenu.**

A dialog box will appear which allows you to select the start and finish sections

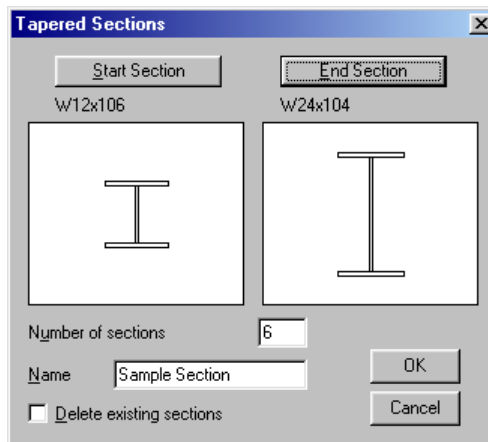

- **Click on the Start Section button**

A dialog box will appear listing the available groups and sections

- **Click on the group and section names of the starting section**
- **Click the OK button**
- **Do the same for the end section.**

The two sections you have chosen will be displayed in the dialog.

- **Type in the number of intermediate sections you want to generate**

The sections properties will be calculated at the mid point of each subdivision of the range between the start and end sections. Section Maker makes an approximation to the intermediate section properties by interpolating between the properties at each end. All the properties except the moments of inertia and the torsion constant are interpolated linearly and will be exactly correct. The moments of inertia and torsion constant are interpolated using a cubic approximation to the variation in property along the tapering member. This will result in a small error in the moments of inertia and torsion constant but in most cases this should not impact significantly on your analysis. If you have a problem, which is sensitive to the value of torsion or moments of inertia, you should determine that this error will not have an adverse impact on your analysis. A quick check of the values at the mid-point will give you a guide to the maximum error.

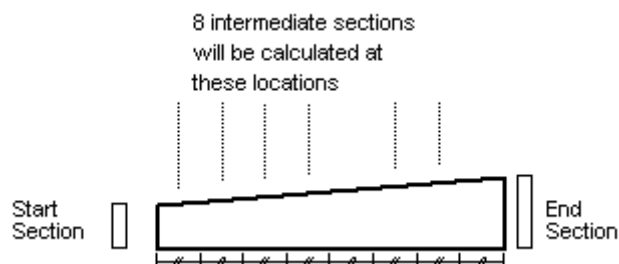

- **Type in a name for the section**

This name will form the basis of the names for the added sections. If "TestShape" is the name you give to the sections, the intermediate sections will be named TestShape1, TestShape2 ... and so on up to TestShapen, where  $n$  is the number of intermediate shapes you requested.

- **If you want to remove the original start and end sections check the check box at the bottom of the dialog**

Most times you will want to do this if you have drawn the sections as the original sections will not be used in the Multiframe analysis. The sections will only be deleted if the groups they belong to are not locked. To unlock a group, see [Locking/Unlocking a Group](#) on page 62.

- **Specify which group you wish to install the intermediate sections into**
- **Click the OK button**

If you want to view or change the properties of the sections which are created, you can view them in the Sections Tab in the Sections Window (see [Viewing Sections](#) on page 69).

#### Note

Remember that whenever you install sections in the library using Section Maker, these new sections will only become available after saving the library and opening it in Multiframe.

## Working with Groups of Materials

---

Section Maker allows you to add, delete and modify the groups of materials stored in a sections library.

In this section:

- [Viewing Groups](#)
- [Locking/Unlocking a Group](#)
- [Adding a Sections Group](#)
- [Editing a Sections Group](#)
- [Duplicating a Group](#)
- [Deleting a Group](#)
- [Reordering Groups](#)

Please note that all the commands described in this section are only available when you have the Materials window activated. Some of the command swill only be available when the Groups tab is activated within this window.

### Viewing Material Groups

---

The groups of materials stored in the Library can be viewed and changed in the Groups tab within Materials Window of Section Maker. A list of all the groups of material within the library is displayed in the Groups tab within this window.

To make the Groups Table visible

- **Choose Materials from the Window menu**
- **Click on the Groups tab in the navigation bar at the bottom of the window.**

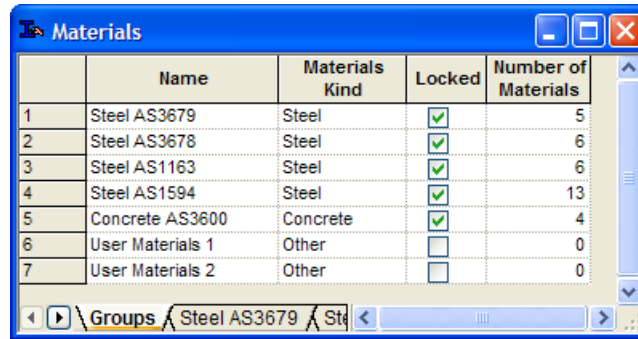

	Name	Materials Kind	Locked	Number of Materials
1	Steel AS3679	Steel	<input checked="" type="checkbox"/>	5
2	Steel AS3678	Steel	<input checked="" type="checkbox"/>	6
3	Steel AS1163	Steel	<input checked="" type="checkbox"/>	6
4	Steel AS1594	Steel	<input checked="" type="checkbox"/>	13
5	Concrete AS3600	Concrete	<input checked="" type="checkbox"/>	4
6	User Materials 1	Other	<input type="checkbox"/>	0
7	User Materials 2	Other	<input type="checkbox"/>	0

### Locking/Unlocking a Group of Materials

Groups are locked using a checkbox in the “Locked” column in the Groups tab in the Materials Window. To unlock a group, clear the checkbox in the “Locked” column of the Groups tab in the Materials window. Groups can also be locked/unlocked via the Group Properties dialog.

### Adding a Materials Group

Material Maker allows you to add groups to or remove groups from the library you currently have open. This makes it more convenient for you to choose materials. If there are groups in the library you never use you could remove them or if there is a table of custom materials you often use you could add them in a separate group in the library.

To Add a Materials Group to the Library

- **Choose Add Materials Group from the Materials submenu under the Library menu**

A dialog box will appear with a field for the group's name, a table showing where key properties will be stored in the group, a text box for the number of fields of data to be stored with each material in the group and a pop-up menu to indicate the shape of materials in the group.

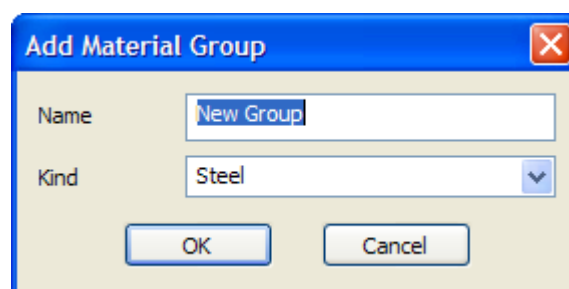

The dialog box titled "Add Material Group" contains the following fields:

- Name:** A text input field containing "New Group".
- Kind:** A dropdown menu currently set to "Steel".
- Buttons:** "OK" and "Cancel" buttons at the bottom.

- **Type in a name for the group**
- **Choose the kind of materials to be stored in this group**

If you have more than one kind of shape or the shape is not one of the standard shapes, leave the shape set to the Unknown Material value.

- **Click the OK button**

The group will be added to the library and will display in the Materials Window.

### Editing a Materials Group

The properties of material groups are edited via the Group table in the Materials Window. To edit the properties of a material group in the current sections library

- **Click on the Group tab in the list a tabs in the bottom corner of the Materials Window.**

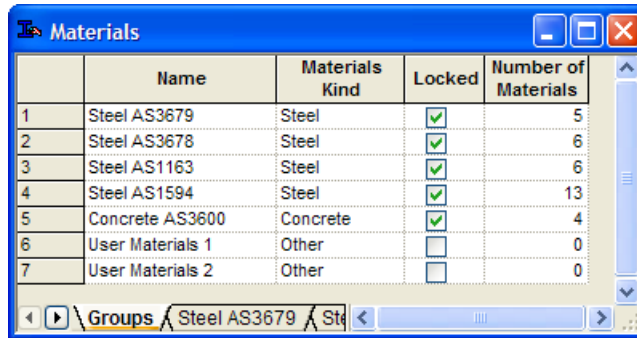

	Name	Materials Kind	Locked	Number of Materials
1	Steel AS3679	Steel	<input checked="" type="checkbox"/>	5
2	Steel AS3678	Steel	<input checked="" type="checkbox"/>	6
3	Steel AS1163	Steel	<input checked="" type="checkbox"/>	6
4	Steel AS1594	Steel	<input checked="" type="checkbox"/>	13
5	Concrete AS3600	Concrete	<input checked="" type="checkbox"/>	4
6	User Materials 1	Other	<input type="checkbox"/>	0
7	User Materials 2	Other	<input type="checkbox"/>	0

The name and kind can be edited directly with the table.

### Duplicating a Group of Materials

To duplicate a group from the Materials Library

- **Choose Duplicate Material Group from the Materials submenu under the Library menu**

A copy of the current group, including all materials contained within the group, will be added to the end of library and made the current group on display in the Materials Window.

### Deleting a Group

To remove a group from the Materials Library

- **Choose Delete Material Group from the Materials submenu under the Library menu**

A list of the groups in the library will be displayed

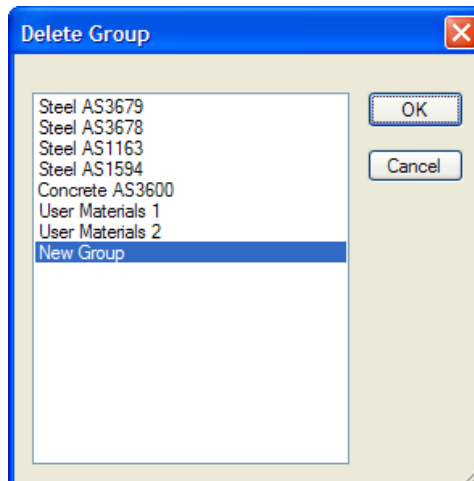

- **Click on the group to be removed**

If you wish to remove more than one group, hold down the shift key while clicking on the names of the other groups

- **Click the OK button**

The groups selected and all the materials stored in them will be removed from the library.

### Reordering Groups

---

The order in which groups appear within the materials library can be modified. To change the order of groups within the materials library

- **Choose Reorder Material Groups from the Materials submenu under the Library menu**

A list of the groups in the library will be displayed

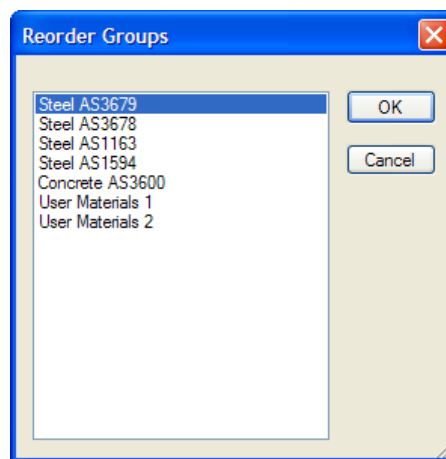

- **Click on the group to be moved, keeping the mouse button depressed**
- **Drag the cursor to locate the new position for the group and release the mouse button.**

If you wish to move more than one group then simply repeat the above two steps for each group to be moved to a new position within the library.

- **Click the OK button**

The new ordering of groups will be saved to the library.

### Working with Materials

---

Section Maker also stores material information in the Sections Library. You can add your own materials and apply them to various parts of your section being designed in the Shape Window. The materials will also be available for use in Multiframe in order to assign the appropriate material properties for use in analysis.

In this section:

- [Viewing Materials](#)
- [Adding a Material](#)
- [Deleting a Material](#)
- [Changing a Material](#)

Please note that all the commands described in this section are only available when you have the Materials tab in the Materials window activated. It is also important to note that only materials groups must be unlocked in order to add, edit or deleted materials from within that group.

### Viewing Materials

The materials stored in the Sections Library can be viewed and changed in the Materials Window of Section Maker. This windows contains a separate table for each group of materials in the library and all the materials contained in the groups are displayed in this table.

To display the Materials Table

- **Choose Material from the Window menu**
- **Click on the tab in the navigation bar at the bottom of the window to select the material group to display.**

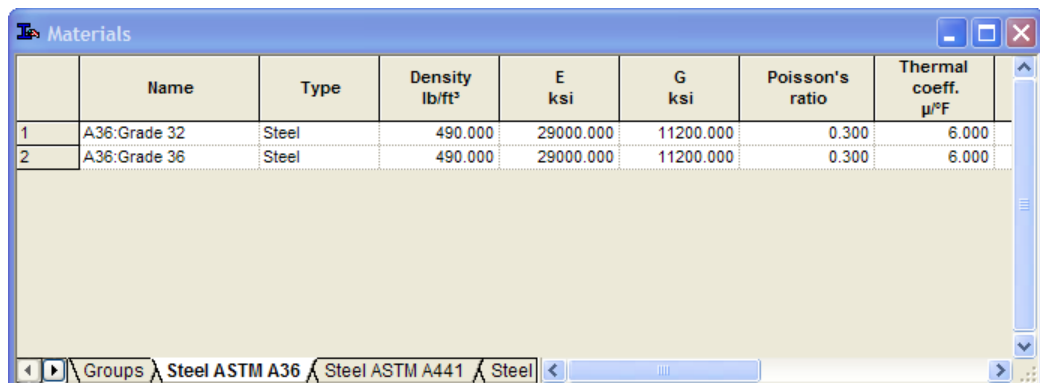

	Name	Type	Density lb/ft <sup>3</sup>	E ksi	G ksi	Poisson's ratio	Thermal coeff. μ°F
1	A36:Grade 32	Steel	490.000	29000.000	11200.000	0.300	6.000
2	A36:Grade 36	Steel	490.000	29000.000	11200.000	0.300	6.000

### Adding a Material

To add a material to the library

- **Choose Add Material from the Materials submenu under the Library menu**

A dialog box will appear allowing you to specify how many materials you wish to add.

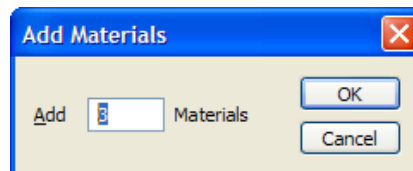

- **Type in the number of materials to be added**
- **Click the OK button**

A number of materials titled “Material 1”, “Materials 2” and so on will be added to the current group. They will initially have all their properties set to default values. You can view and edit the added materials in the table within the Materials Window.

### **Deleting a Material**

---

To delete a material from the library

- **Choose Delete Material from the Materials submenu under the Library menu**

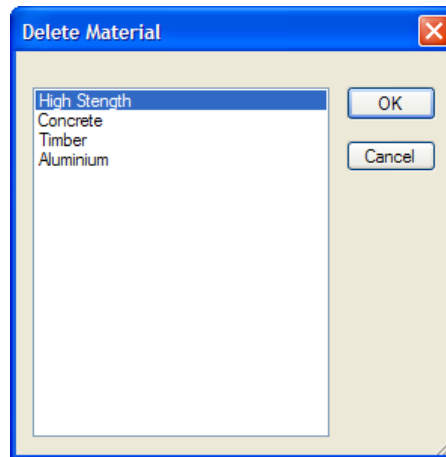

- **Click on the name of the material you want to delete**
- **Click the OK button**

### **Changing a Material**

---

To change the name, pattern or properties of a material

- **Choose Edit Material from the Materials submenu under the Library menu**

The Select Materials dialog will appear.

- **Choose the Material to be edited and click OK.**

The material properties dialog will appear.

- Click on the name of the material you want to edit
- Type in a new name, change the pattern or type in new values for the material's properties
- Click the OK button

Note that only the materials in unlocked materials groups can be edited.

### Reordering Materials

The order in which materials appear within a group can be modified as follows.

- Choose **Reorder Materials** from the **Materials** submenu under the **Library** menu

A list of fields within the group will be displayed

- Click on the material to be moved, keeping the mouse button depressed
- Drag the cursor to locate the new position for the material and release the mouse button.

If you wish to move than one material then simply repeat the above two steps for each material to be moved to a new position within the group.

- **Click the OK button**

The new ordering of materials will be displayed in the Materials Window.

### **Material Colour**

---

A colour may be associated with each material in the library. In Section Maker, the colour of each material is displayed in the table of materials in the Materials Window.

To change the colour associated with a material

- **View the materials properties in a table of materials in the Materials Window**

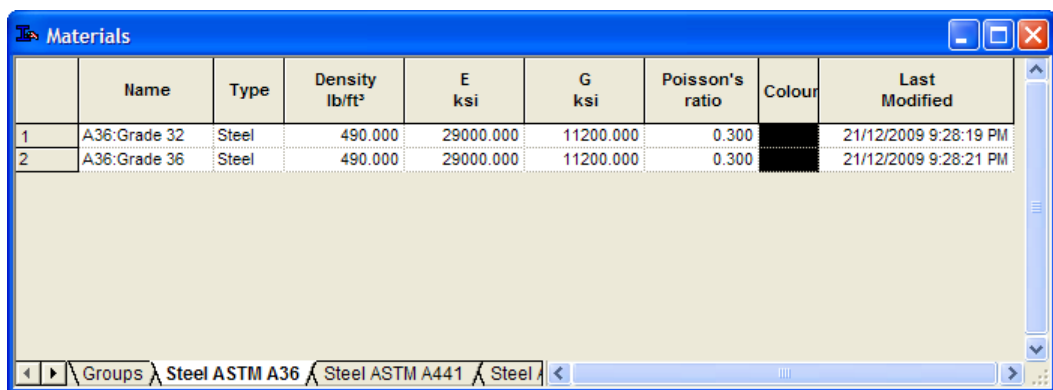

	Name	Type	Density lb/ft <sup>3</sup>	E ksi	G ksi	Poisson's ratio	Colour	Last Modified
1	A36:Grade 32	Steel	490.000	29000.000	11200.000	0.300	[black]	21/12/2009 9:28:19 PM
2	A36:Grade 36	Steel	490.000	29000.000	11200.000	0.300	[black]	21/12/2009 9:28:21 PM

- **Double click on the cell in the Colour column.**

The standard Windows dialog for selecting colours will appear.

- **Click on the new colour for the material**
- **Click the OK button**

Materials colours may also be cut and pasted between materials and the Fill Down function may be used to set ranges of materials to the same colour. Remember that the changes will not be made permanent until you save the library. By default all material colours are set to black.

## Chapter 6

# Section Maker Reference

---

This chapter summarises the overall structure and menu commands of Section Maker. The following sections describe the

- [Windows](#)
- [Sections Window](#)

This window is used for viewing and editing the data stored for each of the groups of sections in the Library. You can use the tabs at the bottom of this window to switch between editing the properties of the groups, or the sections properties data contained within the groups.

### Materials Window

---

This window is used for viewing and editing the data stored for each of the groups of materials in the Library. You can use the tabs at the bottom of this window to switch between editing the properties of the groups, or the properties of the materials contained within the groups.

- [Toolbars](#)
- [Menus](#)

### Windows

---

Section Maker uses a range of graphical, tabular, graph and report windows.

### Shape Window

---

This window is used for drawing sections comprising one or more shapes prior to installing it in the sections library. See [Drawing a Shape](#) on page 31 for more information.

### Data Window

---

This window is used for viewing and editing the data describing the shapes in the Shape window. It can display tables of section properties for the shapes within a section and also displays dimensions of the shapes that make up a section.

### Properties Window

---

This window is used for displaying the calculated sectional properties for the shape in the Shape window.

### Sections Window

---

This window is used for viewing and editing the data stored for each of the groups of sections in the Library. You can use the tabs at the bottom of this window to switch between editing the properties of the groups, or the sections properties data contained within the groups.

### Materials Window

---

This window is used for viewing and editing the data stored for each of the groups of materials in the Library. You can use the tabs at the bottom of this window to switch between editing the properties of the groups, or the properties of the materials contained within the groups.

## Toolbars

---

Users of Section Maker can use the icons on the toolbars to speed up access to some commonly used functions. You can hold your mouse over an icon to reveal a pop-up tip of what the icon does.

### File Toolbar

---



The File toolbar contains icons for open, and saving files.

New Library - Open Library - Save Library - Cut - Copy - Paste - Print Preview - About

### Group Toolbar

---



The Group toolbar contains icons for changing the current group.

Previous Group - Next Group

### View Toolbar

---



The View toolbar contains icons for changing the view in the Shape window.

Zoom - Shrink - Pan - Size To Fit - Toggle Grid - Toggle Axes

### Shape Toolbar

---

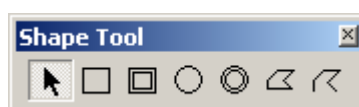

The Shape toolbar contains icons for drawing shapes in the Shape window.

Select - Rectangle - Hollow Rectangle - Circle - Tube - Closed Polygon - Open Polygon

### Geometry Toolbar

---

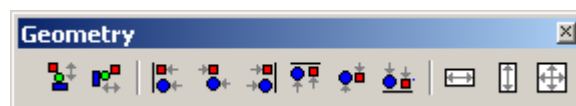

The Geometry toolbar contains icons for modifying the size and layout of shapes in the Shape window.

Stack vertically - Stack horizontally - Align left edges - Align horizontally to centres - Align top edges - Align vertically to centres - Align bottom edges - Make same width - Make same height - Make same size

## Symbols Toolbar

---

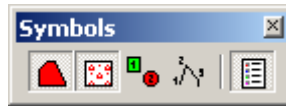

The Symbols toolbar contains icons for displaying symbols in the Shape window.

Fill Shapes – Material Patterns – Shape Numbers – Polygon Numbers – Legend

## Menus

---

Section Maker uses the standard set of Windows menu commands for File, Edit and Windows operations. It also has a range of menus for working with sections and groups of sections.

In this section:

- [File Menu](#)
- [Import Submenu](#)
- [Export Submenu](#)
- [Edit Menu](#)
- [Select Submenu](#)
- [View Menu](#)
- [Geometry Menu](#)
- [Make Equal Size Submenu](#)
- [Align Submenu](#)
- [Align to Centroid Submenu](#)
- [Arrange Submenu](#)
- [Shape Menu](#)
- [Library Menu](#)
- [Sections Submenu](#)

The commands in this submenu are only available if the Sections window is front most. Some commands in this submenu will only be available if a tab displaying section properties window is active.

- **Select Window | Sections to bring the Sections window to the front**
- **Select tab on the bottom of this window other than the Groups tab.**

Also see the section on [Working with Sections](#) on page 68 for more information.

This submenu also contains other commands for working with groups of sections in the library. The commands in this submenu are may only be available if the Groups tab in the Sections window is front most.

- **Select Window | Sections to bring the Sections window to the front**
- **Select the Groups tab on the bottom of this window.**

In some cases, commands acting upon groups of may be available when the Groups window is not front most in which case the command may act upon the group currently being displayed in the window.

See the section on [Working with Groups](#) on page 61 for more information.

---

#### **Add Section**

Add a section or a number of sections to the current group. The sections will be displayed in the current table of sections displayed in the Sections Window where you can type in values for the sections' names and properties.

---

#### **Reorder Sections**

Modify the order of sections within a group.

---

#### **Delete Section**

Delete a section or a number of sections from the current group.

---

#### **Generate Tapered Sections**

Create a number of sections from two existing sections by interpolating the sections properties. This is useful for modelling the sections needed to simulate a tapered sections with a number of intermediate sections. You can use this in conjunction with the subdivide command in Multiframe for modelling tapered members.

See [Generating Tapered Sections](#) on page 74 for more information.

- 
- [Material Submenu](#)
- [Sections Submenu](#)
- [Display Menu](#)
- [Properties Submenu](#)
- [Data Submenu](#)
- [Error! Reference source not found.](#)
- [Symbols Submenu](#)
- [Colours Submenu](#)
- [Legend Submenu](#)
- [Window Menu](#)
- [Sections](#)

Make the Sections Window visible and bring it to the front

---

#### **Materials**

Make the Materials Window visible and bring it to the front

- [Help Menu](#)

---

#### **File Menu**

The File menu contains commands for opening and saving files as well as import and export and printing.

---

#### **New Library**

(Ctrl N)

Use this to start work on a new library. If you have any changes to the current library unsaved, Section Maker will prompt you to save any changes before starting the new work.

---

**Open Library**

(Ctrl O)

Open a library which has previously been saved on disk.

If you have any changes to the current library unsaved, Section Maker will prompt you to save any changes before opening the new file.

---

**Import**

See “Import Submenu”

---

**Export**

See “Export Submenu”

---

**Close Library**

Closes the library and removes all groups and sections from display.

---

**Save Library**

(Ctrl S)

Save the current library data with the same name you saved with last time or the same name the file had when you opened it.

---

**Save Library As**

Save the current library in a file with a new name.

---

**Page Setup**

Set up the printer for printing.

---

**Print Window**

Print the contents of the front window on the screen.

Allows you to set margins, header and footer titles and options on printing the date, time and page numbers.

---

**Print Library**

Print the entire contents of the Sections Library.

---

**Recent File**

Recently opened files will appear at the bottom of the File menu. You can choose them as a shortcut to open them.

---

**Exit**

Leave the Section Maker program. If you have any work unsaved, Section Maker will prompt you to save any changes to the library before quitting.

---

**Import Submenu**

The Import submenu provides you with options to import sections and sections libraries.

---

**DXF**

Imports the shapes in a DXF file into the Shape window.

---

**Text File**

Import the text version of the sections library.

---

**Spacegass Library**

---

Import a sections library from the Spacegass program.

---

**Microstran Library**

---

Import a sections library from the Microstran program.

---

**Export Submenu**

---

The Export submenu allows you to export a sections library.

---

**Text File**

---

Save the sections library in a text file format.

---

**Sections Library v7**

---

Save the sections library in a file format compatible with Multiframe versions 7 and earlier. You can also use this format to move a sections library back to the Macintosh version of Section Maker or Multiframe.

---

**Sections Library v9**

---

Save the sections library in a file format compatible with Multiframe version 8 and 9.

---

**Edit Menu**

---

The Edit menu contains commands for copying and pasting tabular data, selecting objects and working in tables.

---

**Undo**

---

(Ctrl Z)

Undo the last action you carried out. The name of this item will change to reflect the command that can be undone. You can undo up to 20 actions.

---

**Redo**

---

(Ctrl Y)

Redo the last action you undid. The name of this item will change to reflect the command that can be redone.

---

**Cut**

---

(Ctrl X)

Remove the current selection and place it on the clipboard

---

**Copy**

---

(Ctrl C)

Copy the current selection to the clipboard

---

**Paste**

---

(Ctrl V)

Paste the contents of the clipboard into the current selection

---

**Paste Special**

---

(Ctrl V)

Pastes data for entire sections copied from the Sections Table in the Sections Window into the current group. These sections will be appended to the end of the group.

---

**Delete**

Remove the current selection without placing it on the clipboard.

---

**Select**

The Select menu has commands for automatically selecting parts of the drawing in the Shape window.

See “Select Submenu”

---

**Fill Down**

(Ctrl Down Arrow)

Repeat the cell at the top of the list of selected cells in the Data window down the list of selected cells.

---

**Fill Right**

(Ctrl Right Arrow)

Repeat the cell at the left of the list of selected cells in the Data window across the list of selected cells.

---

**Preferences**

Allows the user to modify the applications settings.

---

**Properties**

Displays the properties of the object selected within the Shape Window.

---

**Select Submenu**

The Select submenu has commands for automatically selecting parts of the drawing in the Shape window.

---

**Select All**

(Ctrl A)

Automatically selects all the shapes in the Shape window

---

**Select Polygons**

Automatically selects all the polygonal shapes in the Shape window.

---

**Select Circles**

Automatically selects all the circular shapes in the Shape window

---

**Select Rectangles**

Automatically selects all the rectangular shapes in the Shape window

---

**View Menu**

The View menu contains commands for controlling the display in the Shape window.

---

**Zoom**

(Ctrl W)

Zoom in on part of the current display. A cross-hair will appear and the view to be viewed in close-up may be selected by pressing the mouse button and dragging a rectangle surrounding the area of interest. Release the button to draw the zoomed view.

---

**Pan**

(Ctrl R)

Pan across the drawing displayed in the Shape window. Press and drag in the window to move the drawing.

---

**Shrink**

(Ctrl E)

Reduce the size of the drawing in the Shape window to half its current size.

---

**Size To Fit**

(Ctrl T)

Scale the drawing in the Shape window so that it just fits inside the window.

---

**Size**

Set the maximum and minimum coordinates available in the Shape window. Use this to set up the overall coordinates before you begin drawing a section.

---

**Grid**

Switch on or off the use of the grid in the Shape window and set the spacing of the grid.

---

**Font**

Set the font size and style for the text in the front most window.

---

**Numbers**

Set the type of numeric format you would like to use to display numbers in the front most window. You can choose to use decimal or scientific notation and specify how many digits of precision you wish to display.

---

**Units**

Choose to work in Metric (mm) or English (inches) units.

---

**Colours**

Choose to colours used to display content in the Shape Window.

---

**Status Bar**

Allows you to turn on or off the display of the status bar

---

**Toolbars**

Allows you to turn on or off the display of the toolbars at the top of the Section Maker program window.

See the “Toolbar” section above for more information on the toolbars available in Section Maker.

---

**Geometry Menu**

The Geometry menu contains commands for modifying the geometry and layout of shapes in the Shape window.

---

**Duplicate**

(Ctrl D)

Duplicates all the selected shapes in the Shape window a given number of times in a specified direction. A dialog allows you to enter the spacing in each direction and the number of duplicates to be created.

**Rotate**

---

Rotates all the selected shapes in the Shape window a specified number of degrees about the origin of the axes. A dialog allows you to enter the number of degrees of rotation. Rotation is positive anti-clockwise.

**Rescale**

---

Multiplies the coordinates of all the selected shapes in the Shape window by a specified scaling factor in each axis direction. This has the effect of rescaling the selected shapes by the specified amounts.

**Move**

---

Allows you to move the selected shapes in the Shape window a specified distance. This provides a more accurate way of moving shapes rather than dragging them with the mouse.

**Flip Horizontal**

---

Reflects the selected shapes in the Shape window about a vertical axis passing through the centroid of the area of the selected shapes.

**Flip Vertical**

---

Reflects the selected shapes in the Shape window about a horizontal axis passing through the centroid of the area of the selected shapes.

**Make Equal Size**

---

See “Make Equal Size Submenu”

**Stack Horizontal**

---

Align the selected shapes in the Shape window by moving them horizontally such that the left and right hand sides of adjacent shapes are aligned to each other.

**Stack Vertical**

---

Align the selected shapes in the Shape window by moving them vertically such that the top and bottom sides of adjacent shapes are aligned to each other.

**Align**

---

See “Align Submenu”

**Align To Centroid**

---

See “Align To Centroid Submenu”

**Arrange Submenu**

---

See “Arrange Submenu”

**Group**

---

Group together the selected shapes in the Shape window.

**Ungroup**

---

Ungroup any selected groups in the Shape window.

**Make Equal Size Submenu**

---

The Make Equal Size submenu has commands for resizing shapes drawn in the Shape window such that they have the same width or height as the dominant shape. The dominant shape is the first shape that was selected within the current selection.

---

**Width**

---

Scales the width of all selected shapes to be equal to the width of the first selected shape.

---

**Height**

---

Scales the height of all selected shapes to be equal to the width of the first selected shape.

---

**Both**

---

Scales the width and height of all selected shapes to be equal to the width and height of the first selected shape.

---

**Align Submenu**

---

The Align submenu has commands for moving shapes drawn in the Shape window such that they are aligned to the dominant shape. The dominant shape is the first shape that was selected within the current selection.

---

**Left**

---

Aligns left hand sides of the selected shapes.

---

**Horiz. Centre**

---

Moves shape horizontally to align the centres of the selected shapes.

---

**Right**

---

Aligns right hand sides of the selected shapes.

---

**Top**

---

Aligns top edges of the selected shapes.

---

**Vert. Centre**

---

Moves shape vertically to align the centres of the selected shapes.

---

**Bottom**

---

Aligns bottom edges of the selected shapes.

---

**Align**

---

Align the selected shapes in the Shape window. A dialog will let you specify whether to align the objects to the grid or to each other and whether the align is done vertically or horizontally.

---

**Align to Centroid Submenu**

---

The Align to Centroid submenu moves the selected shapes in the Shape window as a group so that the centroid of the area of the selected shapes is aligned with the origin of either or both of the x and y-axes. You will usually use this command prior to installing the section in the Sections Library as it will make the calculation of all the sections properties relative to a set of axes passing through the centroid of the section.

---

**Centroid**

---

Aligns both x and y centroids to the x and y axes.

---

**X Axis Only**

---

Aligns the x centroid to the x axis

---

**Y Axis Only**

---

Aligns the y centroid to the y axis

## Arrange Submenu

---

The Arrange submenu has commands for controlling the order in which shapes are drawn in the Shape window. If you have the display of material patterns turned on, the shapes drawn last may obscure the shapes drawn first.

### Move To Front

---

Move the selected shapes forward so that they are drawn last and will be in front of all other shapes.

### Move To Back

---

Move the selected shapes backward so that they are drawn first and may be obscured by other shapes.

### Move Forwards

---

Move the selected shapes just in front of the shapes in front of them so that they are drawn after those shapes and will be displayed in front of them on the screen.

### Move Backwards

---

Move the selected shapes just behind the shapes behind them so that they are drawn before those shapes and may be obscured by them.

## Shape Menu

---

The Shape menu contains commands for working with Shapes in the Shape window.

### Place Section

---

Place an existing section from the Sections Library into the Shape window. You can use this to build up a section out of existing sections.

### Place Shape

---

Place a standard structural shape in the Shape window. This provides an easy and precise way of automatically placing an I, C, L or T section or a rectangular or circular tube or a rectangular or circular bar. You can type in dimensions on a sketch of the shape to create it.

### Material

---

Choose a material from the Sections Library to be used for the selected shapes in the Shape window. When the section properties for the section are calculated, these shapes will take their Young's Modulus and Shear Modulus from the data stored with the material. The pattern of the material will be displayed in the shapes that are selected when you use this command.

### Reference Material

---

Choose the material to be used as the reference material in the calculation of section properties for composite sections.

### Convert to Closed Polygon

---

Converts the selected shapes into closed polygons, see [Converting Shapes to Polygons](#) on page 43.

### Merge Polygons

---

Merges the selected polygons. Open polygons will be joined if their ends are connected. Closed polygons will be merged if they overlap.

---

### Validate

Validate the geometry and topology of the shape drawn in the Shape Window.

---

### Add to Library

(Ctrl I)

Install the shapes in the Shape window as a section in the Sections Library. You do this to make the sections data available to Multiframe for analysis or so you can use the section with other shapes in Section Maker in the future.

---

### Library Menu

The Library Menu contains commands for modifying the contents of the sections library. Also see the section on [Working with Libraries](#) on page 57 for more information.

---

### Sections

See "[Sections Submenu](#)"

---

### Materials

See "[Material Submenu](#)"

---

### Group Organiser

Displays a dialog allowing you to move groups of sections from one sections library to another.

---

### Sections Submenu

The commands in this submenu are only available if the Sections window is front most. Some commands in this submenu will only available if a tab displaying section properties window is active.

- **Select Window | Sections to bring the Sections window to the front**
- **Select tab on the bottom of this window other than the Groups tab.**

Also see the section on [Working with Sections](#) on page 68 for more information.

This submenu also contains others commands for working with groups of sections in the library. The commands in this submenu are may only available if the Groups tab in the Sections window is front most.

- **Select Window | Sections to bring the Sections window to the front**
- **Select the Groups tab on the bottom of this window.**

In some cases, commands acting upon groups of may be available when the Groups window is not front most in which case the command may act upon the group currently being displayed in the window.

See the section on [Working with Groups](#) on page 61 for more information.

---

### Add Section

Add a section or a number of sections to the current group. The sections will be displayed in the current table of sections displayed in the Sections Window where you can type in values for the sections' names and properties.

---

### Reorder Sections

Modify the order of sections within a group.

**Delete Section**

---

Delete a section or a number of sections from the current group.

**Generate Tapered Sections**

---

Create a number of sections from two existing sections by interpolating the sections properties. This is useful for modelling the sections needed to simulate a tapered sections with a number of intermediate sections. You can use this in conjunction with the subdivide command in Multiframe for modelling tapered members.

See [Generating Tapered Sections](#) on page 74 for more information.

**Add Sections Group**

---

Add a group to the Sections Library. A new group can be used to store a number of related sections together. You enter a name and type for the group. It will be made the current group displayed in the Sections Window.

**Reorder Sections Groups**

---

Modify the order of groups within the Sections Library.

**Delete Sections Group**

---

Remove a group or a number of groups from the Sections Library.

**Add Field**

---

Add a field to the current group in the Sections Library. A field can be used for storing additional properties for a section. When adding a field, you should enter the name, units and units factor for the field in the Groups Tables in the Add Fields dialog.

**Edit Field**

---

Edit the properties of fields in the current group displayed in the Sections Window.

**Reorder Fields**

---

Modify the order of fields within a group.

**Delete Field**

---

Delete a field or number of fields from the current group in the Sections Library. You should NOT delete any of the first eleven standard fields as Multiframe requires them for analysis.

**Properties**

---

Displays a dialog allowing you to specify the properties and name of the current group.

**Material Submenu**

---

The Material submenu contains commands for working with materials in the sections library. The commands in this submenu are only available if the Materials Window is front most.

- **Select Window | Library to bring the Materials window to the front**
- **Select the Materials tab on the bottom of this window.**

Also see the section on [Working with Groups](#) of Materials Section Maker allows you to add, delete and modify the groups of materials stored in a sections library.

In this section:

- [Viewing Groups](#)
- [Locking/Unlocking a Group](#)
- [Adding a Sections Group](#)
- [Editing a Sections Group](#)
- [Duplicating a Group](#)
- [Deleting a Group](#)
- [Reordering Groups](#)

Please note that all the commands described in this section are only available when you have the Materials window activated. Some of the command will only be available when the Groups tab is activated within this window.

### Viewing Material Groups

The groups of materials stored in the Library can be viewed and changed in the Groups tab within Materials Window of Section Maker. A list of all the groups of material within the library is displayed in the Groups tab within this window.

To make the Groups Table visible

- **Choose Materials from the Window menu**
- **Click on the Groups tab in the navigation bar at the bottom of the window.**

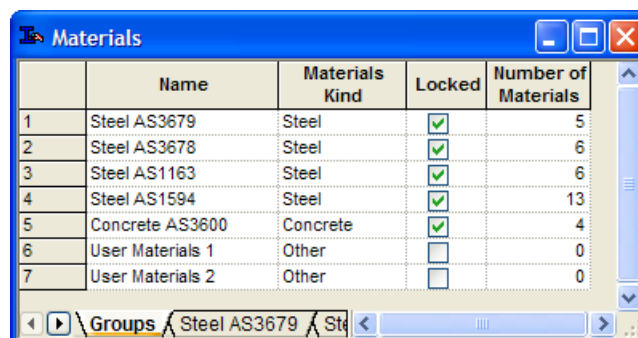

	Name	Materials Kind	Locked	Number of Materials
1	Steel AS3679	Steel	<input checked="" type="checkbox"/>	5
2	Steel AS3678	Steel	<input checked="" type="checkbox"/>	6
3	Steel AS1163	Steel	<input checked="" type="checkbox"/>	6
4	Steel AS1594	Steel	<input checked="" type="checkbox"/>	13
5	Concrete AS3600	Concrete	<input checked="" type="checkbox"/>	4
6	User Materials 1	Other	<input type="checkbox"/>	0
7	User Materials 2	Other	<input type="checkbox"/>	0

### Locking/Unlocking a Group of Materials

Groups are locked using a checkbox in the “Locked” column in the Groups tab in the Materials Window. To unlock a group, clear the checkbox in the “Locked” column of the Groups tab in the Materials window. Groups can also be locked/unlocked via the Group Properties dialog.

### Adding a Materials Group

Material Maker allows you to add groups to or remove groups from the library you currently have open. This makes it more convenient for you to choose materials. If there are groups in the library you never use you could remove them or if there is a table of custom materials you often use you could add them in a separate group in the library.

To Add a Materials Group to the Library

- **Choose Add Materials Group from the Materials submenu under the Library menu**

A dialog box will appear with a field for the group's name, a table showing where key properties will be stored in the group, a text box for the number of fields of data to be stored with each material in the group and a pop-up menu to indicate the shape of materials in the group.

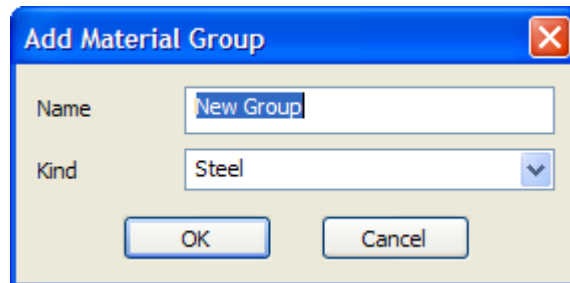

- **Type in a name for the group**
- **Choose the kind of materials to be stored in this group**

If you have more than one kind of shape or the shape is not one of the standard shapes, leave the shape set to the Unknown Material value.

- **Click the OK button**

The group will be added to the library and will display in the Materials Window.

### Editing a Materials Group

The properties of material groups are edited via the Group table in the Materials Window. To edit the properties of a material group in the current sections library

- **Click on the Group tab in the list a tabs in the bottom corner of the Materials Window.**

	Name	Materials Kind	Locked	Number of Materials
1	Steel AS3679	Steel	<input checked="" type="checkbox"/>	5
2	Steel AS3678	Steel	<input checked="" type="checkbox"/>	6
3	Steel AS1163	Steel	<input checked="" type="checkbox"/>	6
4	Steel AS1594	Steel	<input checked="" type="checkbox"/>	13
5	Concrete AS3600	Concrete	<input checked="" type="checkbox"/>	4
6	User Materials 1	Other	<input type="checkbox"/>	0
7	User Materials 2	Other	<input type="checkbox"/>	0

The name and kind can be edited directly with the table.

### Duplicating a Group of Materials

To duplicate a group from the Materials Library

- **Choose Duplicate Material Group from the Materials submenu under the Library menu**

A copy of the current group, including all materials contained within the group, will be added to the end of library and made the current group on display in the Materials Window.

### **Deleting a Group**

---

To remove a group from the Materials Library

- **Choose Delete Material Group from the Materials submenu under the Library menu**

A list of the groups in the library will be displayed

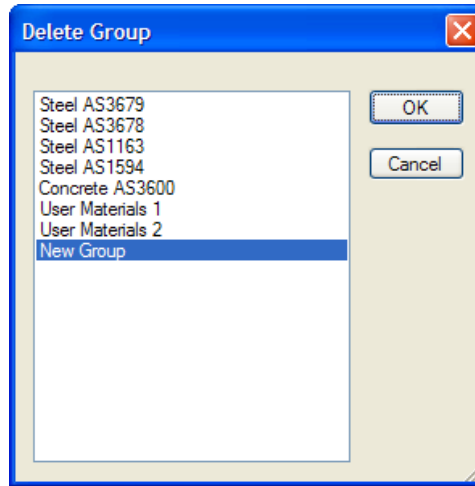

- **Click on the group to be removed**

If you wish to remove more than one group, hold down the shift key while clicking on the names of the other groups

- **Click the OK button**

The groups selected and all the materials stored in them will be removed from the library.

### **Reordering Groups**

---

The order in which groups appear within the materials library can be modified. To change the order of groups within the materials library

- **Choose Reorder Material Groups from the Materials submenu under the Library menu**

A list of the groups in the library will be displayed

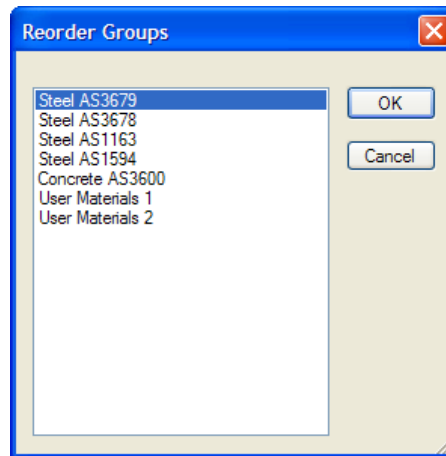

- **Click on the group to be moved, keeping the mouse button depressed**
- **Drag the cursor to locate the new position for the group and release the mouse button.**

If you wish to move than one group then simply repeat the above two steps for each group to be moved to a new position within the library.

- **Click the OK button**

The new ordering of groups will be saved to the library.

Working with Materials on page 76 for more information.

---

#### **Add Material**

Add a material to the Sections Library. This material will then be available for use in any of the sections you draw. You enter the properties for the material and can design a pattern to be used in shapes made from this material

---

#### **Delete Material**

Remove a material or a number of materials from the Sections Library.

---

#### **Edit Material**

Change the name, properties or pattern of a material stored in the Sections Library.

---

#### **Colours**

Change the colours associated with the materials stored in the Sections Library.

---

#### **Display Menu**

The items in the Display menu control the display of tables in the Data and Properties windows and the symbols in the Shape window.

---

#### **Properties**

See [Properties Submenu](#) on page 97.

---

#### **Data**

See [Data Submenu](#) on page 98.

---

#### **Library**

See [Error! Reference source not found.](#) on page 98.

---

**Symbols**

---

See [Symbols Submenu](#) on page 98.

---

**Colours**

---

See [Colours Submenu](#) on page 99.

---

**Legend**

---

See [Legend Submenu](#) on page 99.

---

**Properties Submenu**

---

The Properties submenu contains commands for selecting the table displayed in the Properties Window.

---

**X-Y**

---

Display the table of section properties for the shape drawn in the Shape window. Only properties related to the x-y axes will be displayed in this table.

---

**Principal**

---

Display the table of section properties for the shape drawn in the Shape window. Only properties related to the principal axes will be displayed in this table.

---

**Dimensions**

---

Display the table of section properties for the shape drawn in the Shape window. Only the dimensional properties will be displayed in this table.

---

**Current Group**

---

Display the table of section properties for the shape drawn in the Shape window. The properties listed in this table will correspond to the fields contained within the current. The units used in this table will correspond to the units associated with the data in the current group.

---

**Frame Group**

---

Display the table of section properties for the shape drawn in the Shape window. The properties listed in this table will correspond to the fields contained within Multiframe's Frame group..

---

**All**

---

Display the table with all section properties for the shape drawn in the Shape window.

---

**Data Submenu**

---

The Data submenu contains commands for selecting the table displayed in the Data Window.

---

**Properties**

---

Display the table of section properties for each of the individual shapes that make up the total shape drawn in the Shape window.

---

**Polygons**

---

Display the table of polygon coordinates, material types and thicknesses for the polygons in the Shape window.

**Circles**

---

Display the table of circle coordinates, material types and thicknesses for the circles in the Shape window.

**Rectangles**

---

Display the table of rectangle coordinates, material types and thicknesses for the rectangles in the Shape window.

**Symbols Submenu**

---

The Symbols submenu contains commands for controlling how shapes are drawn in the shape windows and how these shapes are labelled.

**Shape Numbers**

---

Turns on and off the display of the number of each shape in the Shape window. The number is displayed in the centre of the shape and is prefixed by a letter code for the type of shape, p for polygon, c for circle and r for rectangle. You can use these numbers to refer to the shapes in the Data window.

**Polygon Numbers**

---

Turns on and off the display of the number of each vertex of each polygon in the Shape window. You can use these numbers to refer to the polygon coordinates displayed in the Data window.

**Axes**

---

Turn on or off the display of axes in the Shape window

**Principal Axes**

---

Turn on or off the display of the principal axes of the section in the Shape window

**Overall Dimensions**

---

Turn on or off the display of the overall depth and width of the section in the Shape window

**Interior Dimensions**

---

Turn on or off the display of the minor dimension of the section drawn in the Shape window

**Fill Shapes**

---

Turn on or off the display of shapes as solid objects. When fill is turned off, the outline of shapes will be displayed using the current colour scheme.

**Material Patterns**

---

Turn on or off the display of material patterns when drawing the fill colour of the shapes drawn in the Shape window.

**Colours Submenu**

---

The Colours submenu contains commands for choosing the colours used to display shapes in the Shape Window.

**No Colour**

---

Display shapes in the Shape Window in black and white only.

---

**By Material**

---

Display shapes in the Shape Window using a separate colour for each Material.

---

**By Shape**

---

Display shapes in the Shape Window using a separate colour for each Shape.

---

**By Shape Type**

---

Display shapes in the Shape Window using a separate colour for each type of Shape.

---

**Legend Submenu**

---

The Legend submenu contains commands for controlling the display of the legend in the Shape window.

---

**Visible**

---

Turn on or off the display of the legend in the Shape window.

---

**Top Left**

---

Display the legend in the top left corner of the Shape window.

---

**Top Right**

---

Display the legend in the top right corner of the Shape window.

---

**Bottom Left**

---

Display the legend in the bottom left corner of the Shape window.

---

**Bottom Right**

---

Display the legend in the bottom right corner of the Shape window.

---

**Title Font**

---

Select the font used to display the title of the legend drawn in the Shape Window.

---

**Font**

---

Select the font used to display the text of each item listed in the legend drawn in the Shape Window.

---

**Item Colours**

---

Select the colour of each item displayed in the legend drawn in the Shape Window.

---

**Window Menu**

---

The items in the Window menu control the display of windows in Section Maker

---

**Tile Horizontal**

---

Arranges the currently visible windows down the screen to fill the screen.

---

**Tile Vertical**

---

Arranges the currently visible windows across the screen to fill the screen.

---

**Arrange Icons**

---

Tidies up the display of window icons in the program window.

---

**Drawing Layout**

---

Resizes the windows so that the Shape, Properties and Data windows are conveniently located for drawing new sections and viewing their properties.

**Shape**

---

Make the Shape window visible and bring it to the front.

**Data**

---

Make the Data window visible and bring it to the front.

**Properties**

---

Make the Properties window visible and bring it to the front.

**Sections**

---

Make the Sections Window visible and bring it to the front

**Materials**

---

Make the Materials Window visible and bring it to the front

**Help Menu**

---

The Help menu contains commands for accessing Section Maker's on-line help system.

**Section Maker Help**

---

Gives access to the Section Maker manuals.

**About Section Maker**

---

Displays version information for this version of Section Maker.



## Appendix A - File Formats

---

In appendix A: [Section Library Text File Format](#).

### Section Library Text File Format

---

When you save a sections library in text format the data is formatted according to the following procedure-

```

Number of groups in the file
For each group
  1 if the group is locked or 0 otherwise
  Name of the group
  Number of the group in the library
  Kind of material 1 for steel, 2 for concrete, 3 for timber,
    4 for aluminium, 0 otherwise
  Shape of sections in the group I=1, Channel=2, Equal
    Angle=3, Unequal Angle =4, Tee=5, Rectangular Tube =6,
    Square Tube (SHS)=7, Circular Tube=8, Circular bar=9,
    Rectangular bar=10 , Folded Cee=11, Folded Zed=12
  No of sections, no of fields and no of analysis properties in the group
  Position of the analysis properties in the fields of the group
  For the number of fields
    Name of the field
  For the number of fields
    Units of the field
  For the number of fields
    Factor of the field
  For the number of sections
    Name of the section
    For the number of fields
      Value of the field for this section
For each material
  Name of the group
  Number of the group in the library
  Kind of material 1 for steel, 2 for concrete, 3 for timber,
    4 for aluminium, 0 otherwise
  Density of the material
  Thermal Coefficient of the material
  Poisson's Ratio of the material
  Young's Modulus of the material
  Shear Modulus of the material
  Yield Stress of the material
  Ultimate Stress of the material

```

The easiest way to understand the format is to use the Export command to save a text file from a sample library and to review or modify that text file.



## References

---

You may find the following books useful to refer to if you need information on the methods used to calculate sections properties.

➤ **Roark's Formulas for Stress and Strain, 6th Edition**

W C Young, McGraw Hill, New York, 1989

➤ **The Behaviour and Design of Steel Structures**

N S Trahair and M A Bradford, Chapman and Hall, London, 1988

➤ **Formulas for Stress, Strain and Structural Matrices**

W D Pilkey, John Wiley and Sons, New York, 1994

➤ **Elements of Strength of Materials**

S P Timoshenko and D H Young, Van Nostrand, 1968



## Index

---

### A

About Section Maker, 100  
 Add  
   Field, 66, 96  
   Group of Materials, 77  
   Group of Sections, 62  
   Material, 80, 97  
   Section, 95  
   Sections Group, 96  
 Add Section to Library, 17, 50, 69, 95  
 Adding a Material, 80  
 Align, 92, 93  
   Centroid, 17, 92, 93  
   Shapes, 42  
   Submenu, 93  
 Arrange  
   Icons, 100  
   Submenu, 92, 94  
 Axes, 98

### B

Backspace, 23

### C

Centroid, 44, 93  
 Changing a Material, 81  
 Changing Section Properties, 71  
 Circle Tool, 35  
 Circles Table, 98  
 Close Library, 88  
 Colour  
   Materials, 82  
 Colour by  
   Material, 99  
   Shape, 99  
   Shape Type, 99  
 Colours Submenu, 97, 99  
 Convert to Polygon, 94  
 Converting Shapes to Polygons, 43  
 Copy, 89  
   Shape, 39  
   Table Data, 28  
 Ctrl -Click, 22  
 Ctrl key, 23  
 Current Group Properties, 98  
 Custom Shape Data, 73  
 Cut, 89

### D

Data  
   Submenu, 97, 98  
   Window, 85, 100  
 Delete, 23, 89  
   Field, 68, 96  
   Material, 80, 97  
   Material Group, 78  
   Section, 70, 96  
   Section Group, 64  
   Sections Group, 96  
   Shape, 40  
 Dimensions, 97  
 Display Menu, 97  
 Double -Click, 22  
 Dragging the Shape, 14  
 Drawing a Shape, 11, 15, 31  
 Drawing Layout, 100  
 Drawing Tools  
   Circle, 35  
   Hollow Rectangle, 34  
   Open Polygon, 37  
   Polygon, 37  
   Rectangle, 33  
   Tube, 35  
 Duplicate  
   Material Group, 78  
   Section Group, 64  
 Duplicate Shape, 40, 91  
 DXF, 88

### E

Edit  
   Field, 66, 96  
   Material, 81, 97  
   Menu, 89  
 Exit, 88  
 Export, 88  
 Export Submenu, 89

### F

Fields, 58  
   Add, 66  
   Delete, 68  
   Property, 66  
   Reorder, 68  
 File Menu, 87  
 File Toolbar, 85  
 Fill Down, 90

Fill Right, 90  
Fill Shapes, 99  
Flip Horizontal, 92  
Flip Vertical, 92  
Font, 91  
Frame Group Properties, 98

## **G**

Generate Tapered Sections, 74  
Geometry  
    Make Equal Size, 92  
    Menu, 91  
Geometry Toolbar, 86  
Grid, 15, 91  
Group, 92  
    Toolbar, 86  
    View, 61  
Group Organiser, 59, 95  
Grouping Shapes, 44

## **H**

Help Menu, 100  
Hollow rectangle Tool, 34

## **I**

Import, 88  
Import Submenu, 88  
Importing a Shape, 46  
Interior Dimensions, 99

## **K**

Keyboard Short Cuts, 22

## **L**

Legend, 53  
Legend Submenu, 97, 99  
Library, 57  
    Add Section, 17, 50  
    Close, 88  
    Frame Group, 10  
    Menu, 95  
    New, 58, 87  
    Open Existing, 58, 87  
    Save, 19, 59, 88  
    Save As, 88  
    Saving as Text, 59  
    Sharing with Multiframe, 9  
    Submenu, 97

## **M**

Make Equal Size, 42, 92  
Make Equal Size Submenu, 92  
Material, 94  
    Change, 81

    Select Material, 16  
    Set, 47  
    Submenu, 95  
    Submenu, 96  
    Type, 47

Material Colour, 97

Material Group  
    Delete, 78  
    Duplicate, 78  
    View, 76

Material Groups  
    Reorder, 79

Material Patterns, 99

Materials  
    Add, 80  
    Colour, 82  
    Delete, 80  
    Reorder, 82  
    View, 80  
    Window, 85, 100

Materials Group  
    Add, 77  
    Locking, 77  
    Properties, 77

Menus, 87  
    Display, 97  
    Edit, 89  
    File, 87  
    Geometry, 91  
    Library, 95  
    Shape, 94  
    View, 90  
    Window, 100

Merge Polygons, 94

Merging Polygons, 43

Merging Polygons, 43

Microstran Library, 89

Mirror Shape, 41

Mouse techniques, 21

Move, 39, 92  
    Backwards, 94  
    Forwards, 94  
    Shape, 38  
    To Back, 94  
    To Front, 94

## **N**

New Library, 58, 87  
No Colour, 99  
Notation, 3  
Numbers, 91

## **O**

Open Library, 58, 87

- Open Polygon Tool, 37
- Overall Dimensions, 99
- P**
- Page Setup, 88
- Pan, 24, 90
- Paste, 89
  - Shape, 39
  - Table Data, 28
- Paste Special, 89
- Place
  - Section, 13, 94
  - Shape, 12, 94
- Polygon Numbers, 98
- Polygon Tool, 37
- Polygons Table, 98
- Principal Axes, 99
- Principal Properties, 97
- Print
  - Library, 29, 88
  - Section, 19
  - Set up, 28
  - Window, 29, 88
- Printing, 28
- Properties, 90, 96
  - Materials Group, 77
  - Sections Group, 63
  - Submenu, 97
  - Submenu, 97
  - Table, 98
  - Window, 49, 85, 100
- R**
- Recent File, 88
- Rectangle Tool, 33
- Rectangles Table, 98
- Redo, 89
- Reference Material, 94
- References, 103
- Reflecting Shapes, 41
- Reorder
  - Fields, 68, 96
  - Groups of Materials, 79
  - Groups of Sections, 65
  - Materials, 82
  - Sections, 73, 95
  - Sections Groups, 96
- Rescale Shape, 41, 92
- Resizable Dialogs, 23
- Resizing a Shape, 40
- Rotate Shape, 13, 40, 91
- S**
- Save
  - Library, 19
  - Save Library, 88
  - Save Library As, 88
  - Saving a Library, 59
  - Saving as Text, 59
  - Scrolling, 23
  - Section
    - Add, 69
    - Align, 17
    - Centroid, 44
    - Change, 71
    - Colour, 73
    - Composite, 9
    - Delete, 70
    - Geometric Data, 73
    - Overlap, 7
    - Print, 19
    - Properties, 49
    - Property Calculations, 7
    - Reorder, 73
    - View, 69
  - Section Group
    - Delete, 64
    - Duplicate, 64
  - Section Groups
    - Reorder, 65
  - Section Properties, 58
  - Sections
    - Submenu, 95
    - Window, 85, 100
  - Sections Group
    - Add, 62
    - Locking, 62
    - Properties, 63
  - Sections Library v7, 89
  - Sections Library v9, 89
  - Select, 90
    - All, 90
    - Circles, 90
    - Material, 16
    - Polygons, 90
    - Rectangles, 90
  - Shape
    - Add To Library, 95
    - Align, 42
    - Convert to Polygon, 94
    - Converting to Polygons, 43
    - Copy, 39
    - Delete, 40
    - Draw, 31
    - Draw, 15
    - Drawing Tools, 33
    - Duplicate, 40

- Grid, 32
- Group, 44
- Import, 46
- Make Equal Size, 42
- Material, 47, 94
- Menu, 94
- Merge Polygons, 94
- Mirror, 41
- Move, 14, 38
- Paste, 39
- Place Section, 13, 46, 94
- Place Shape, 12, 45, 94
- Precision Move, 39
- Properties, 43
- Reference Material, 94
- Rescale, 41
- Resize, 40
- Rotate, 13, 40
- Select Material, 16
- Stack, 42
- Tapered Section, 96
- Tapered Sections, 74
- Toolbar, 86
- Validate, 95
- Window, 85, 100
- Window Size, 11, 32
- Shape Numbers, 98
- Shape Window, 24
- Shear area, 71
- Shear Modulus, 47
- Shift Key, 23
- Shift-Click, 22
- Shrink, 25, 91
- Size, 91
- Size To Fit, 25, 91
- Spacegass Library, 88
- Stack Horizontal, 92
- Stack Vertical, 92
- Stacking Shapes, 42
- Standard Shapes, 45
- Starting Section Maker, 7, 11
- Status Bar, 91
- Symbols, 51
  - Axes, 52
  - Dimensions, 52
  - Fill, 52
  - Material Patterns, 52
  - Polyline Numbers, 51
  - Principal Axes, 52
  - Shape Numbers, 51
  - Submenu, 97, 98
  - Toolbar, 86
- System Requirements, 7

## ***T***

- Table, 25
  - Column Width, 25
  - Copy, 27
  - Copy Section, 28
  - Edit, 26
  - Number Style, 26
  - Paste, 27
  - Paste Section, 28
  - Select, 27
  - Text Style, 25
- Table Windows, 25
- Tapered Section, 96
- Text File, 88, 89
- Tile
  - Horizontal, 100
  - Vertical, 100
- Toolbars, 85, 91
- Tube Tool, 35

## ***U***

- Undo, 89
- Ungroup, 92
- Units, 91
  - Common, 67

## ***V***

- Validate, 95
- Validating, 50
- View Menu, 90
- View Toolbar, 86
- Viewing Groups, 61
- Viewing Material Groups, 76
- Viewing Materials, 80
- Viewing Properties, 49
- Viewing Sections, 18, 69

## ***W***

- Window
  - Grid, 15, 32
  - Menu, 100
  - Pan, 24
  - Shrink, 25
  - Size, 11, 32
  - Size To Fit, 25
  - Zoom, 24
- Windows, 85
  - Data, 85
  - Materials, 85
  - Properties, 49, 85
  - Sections, 85
  - Shape, 85

**X**

X Axis Only, 93  
X-Y Properties, 97

**Y**

Y Axis Only, 93

Young's Modulus, 47

**Z**

Zoom, 24, 90